

User Manual

---

Ultrasonic Anemometer

(Part 1405-PK-200, Heated)

(Part 1405-PK-300, Non -Heated)

Doc No: 1405-PS-0030

Issue 2



Applies to units with Serial Number 16100001 onwards  
with Firmware 2368-109-01 onwards

Gill Instruments Limited  
Saltmarsh Park, 67 Gosport Street, Lymington,  
Hampshire, SO41 9EG, UK  
Tel: +44 1590 613500, Fax: +44 1590 613555  
Email: [anem@gillinstruments.com](mailto:anem@gillinstruments.com) Website: [www.gillinstruments.com](http://www.gillinstruments.com)



## Contents

<b>1</b>	<b>FOREWORD4</b>	
<b>2</b>	<b>INTRODUCTION 4</b>	
<b>3</b>	<b>FAST TRACK SET-UP 4</b>	
<b>4</b>	<b>PRINCIPLE OF OPERATION 5</b>	
<b>5</b>	<b>SPECIFICATION 7</b>	
<b>6</b>	<b>PRE-INSTALLATION 9</b>	
6.1	EQUIPMENT SUPPLIED	9
6.1.1	<i>WindSonic M Part Numbers</i>	9
6.2	PACKAGING	10
6.3	INSTALLATION REQUIREMENTS	10
6.4	CABLE ASSEMBLY	11
<b>7</b>	<b>INSTALLATION 15</b>	
7.1	INSTALLATION GUIDELINES	15
7.2	BENCH SYSTEM TEST	16
7.3	ELECTRICAL	16
7.3.1	<i>Cable</i>	16
7.3.2	<i>Power supply</i>	17
7.4	CONNECTING TO A PC USING RS232 (DEFAULT SENSOR)	18
7.5	CHANGING A DEFAULT SET WINDSONIC M RS232 OUTPUT (MODE E3) TO RS422 OUTPUT (MODE, E2).	19
7.6	USING SAFE MODE TO CHANGE AN RS422 SET SENSOR BACK TO RS232 OPERATION.	20
7.7	CONNECTING TO A GILL WINDDISPLAY	21
7.8	CONNECTING AN RS422 OUTPUT WINDSONIC M TO A PC WITH AN RS422 INTERFACE/CONVERTER.	22
7.9	USING 2 WIRE RS485 POINT TO POINT ONLY	23
7.10	ANALOGUE OUTPUT	23
<b>8.</b>	<b>Mechanical 24</b>	
8.1	ORIENTATION	24
8.2	<i>Alignment</i>	24
8.3	<i>Mounting</i>	24
8.4	<i>Earthing or Grounding</i>	26
8.5	<i>Heating</i>	26
<b>9</b>	<b>MESSAGE FORMATS 27</b>	
9.1	GILL FORMAT– POLAR, CONTINUOUS (DEFAULT FORMAT)	27
9.2	GILL FORMAT – UV, CONTINUOUS	30
9.3	GILL FORMAT – POLLED (POLAR OR UV)	31
9.4	NMEA FORMAT (NMEA STATUS CODES)	32
9.5	NMEA FORMAT (GILL STATUS CODES)	33
9.6	GILL FORMAT – TUNNEL MODE (UU, CONTINUOUS)	33
9.7	ANALOGUE OUTPUTS AND OPTIONS	34
9.7.1	<i>Low wind speeds (below 0.05 m/s).</i>	34
<b>10</b>	<b>CONFIGURING 35</b>	
10.1	WIND	35

10.2	WINDVIEW	39
10.3	CONFIGURING USING HYPERTERMINAL	44
10.4	ENTERING CONFIGURATION MODE	44
10.5	RETURNING TO MEASUREMENT MODE	44
10.6	CHECKING THE CONFIGURATION	45
10.7	CHANGING A SETTING	45
10.7.1	<i>Command List</i>	46
	<i>Bx - Baud rate</i>	47
	<i>Cx - settings</i>	47
	<i>Dx - Diagnostic and Configuration Command (See Section 10.8)</i>	47
	<i>Ex - Communications Protocol</i>	47
	<i>Fx - Data and parity options</i>	47
	<i>Gx - settings</i>	48
	<i>Hx - Power-up Message</i>	48
	<i>Kxx to Kxxxx - Minimum Direction Velocity</i>	48
	<i>Lx - Message Terminator</i>	49
	<i>Mx to Mxx - Message Format</i>	49
	<i>Nx - Node Address</i>	49
	<i>Ox - ASCII Output Format</i>	50
	<i>Px to Pxx - Output Rate</i>	50
	<i>Q - Measurement Mode</i>	50
	<i>Sx - Settings</i>	50
	<i>Tx - Settings</i>	50
	<i>Ux - Output Units</i>	51
10.8	CONFIGURATION / DIAGNOSTIC INFORMATION	52
<b>11</b>	<b>MAINTENANCE &amp; FAULT-FINDING 53</b>	
11.1	CLEANING	53
11.2	SERVICING	53
11.3	FAULT FINDING	53
11.4	RETURNING UNIT	54
11.5	STATUS	54
<b>12</b>	<b>TESTS 54</b>	
12.1	BENCH TEST	54
12.2	SELF-TEST (STILL AIR)	55
12.3	CALIBRATION	55
<b>13</b>	<b>APPENDICES 56</b>	
13.1	GLOSSARY & ABBREVIATIONS	56
13.2	GUARANTEE	56
13.3	WINDSONIC M ELECTRICAL CONFORMITY	57

## 1 FOREWORD

Thank you for purchasing the WindSonic M manufactured by Gill Instruments Ltd. The unit has no customer serviceable parts and requires no calibration or maintenance. To achieve optimum performance we recommend that you read the whole of this manual before proceeding with use. Do NOT remove black "rubber" transducer caps.

Gill products are in continuous development and therefore specifications may be subject to change and design improvements without prior notice.

The information contained in this manual remains the property of Gill Instruments and should not be copied or reproduced for commercial gain.

## 2 INTRODUCTION

With an impressive robust, corrosion-free, aluminium alloy housing and optional anti-icing heating system the WindSonic M wind sensor is recommended for use in harsh environmental industrial conditions and is particularly suited to marine, offshore (ships, data buoys) and land based installations.

The Gill WindSonic M wind sensor has no moving parts, outputting wind speed and direction. The units of wind speed, output rate and formats are all user selectable.

The WindSonic M can be used in conjunction with a PC, data logger or other device, provided it is compatible with one of the standard communication formats provided by the WindSonic M.

WindSonic M set for RS422 output is designed to connect directly to the Gill WindDisplay unit to provide a complete wind speed direction system.

WindSonic M may be configured using Wind software which is available, free of charge, from the Gill website [www.gillinstruments.com](http://www.gillinstruments.com). The output message format can be configured in Gill format, in Polar or UV (2-axis) format, and to either Polled (requested by host system) or Continuous output. Alternatively, it can be configured in NMEA (0183 Version 3). These are described in Section 9 MESSAGE FORMATS.

**The WindSonic M is available with a Heating system or without a Heating system.**

## 3 FAST TRACK SET-UP

If you are in a hurry to try out the WindSonic M and are familiar with Gill equipment and coupling to a PC using RS232, go to the following sections:

- Section 7 INSTALLATION
- Section 9 MESSAGE FORMATS
- Section 10 CONFIGURING

After you have successfully set up the WindSonic M, we strongly advise that you then go back and read the rest of the manual to ensure that you get the best results from the WindSonic M.

## 4 PRINCIPLE OF OPERATION

The WindSonic M measures the times taken for an ultrasonic pulse of sound to travel from the North transducer to the South transducer, and compares it with the time for a pulse to travel from S to N transducer. Likewise times are compared between West and East, and E and W transducer.

If, for example, a North wind is blowing, then the time taken for the pulse to travel from N to S will be faster than from S to N, whereas the W to E, and E to W times will be the same. The wind speed and direction can then be calculated from the differences in the times of flight on each axis. This calculation is independent of factors such as temperature.

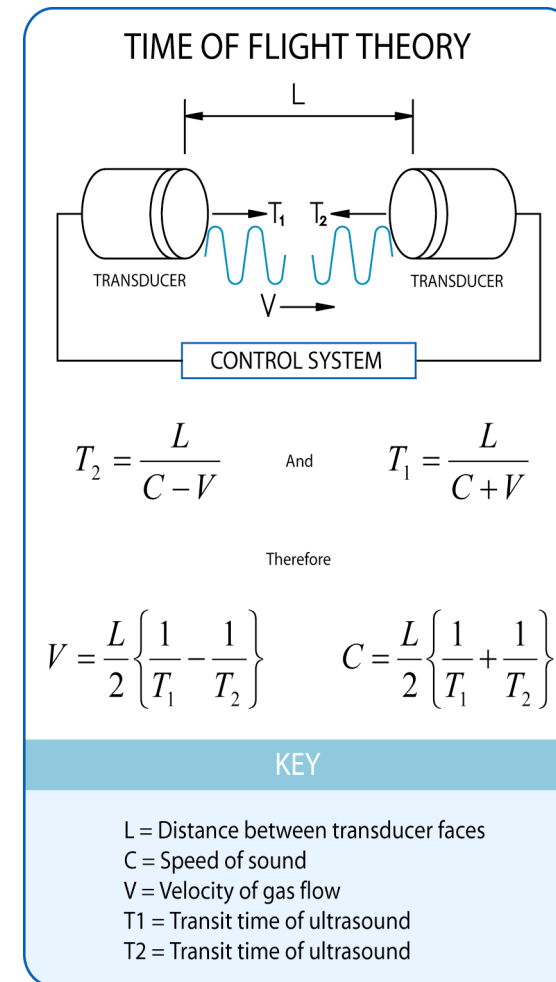

Figure 1 Time of Flight details

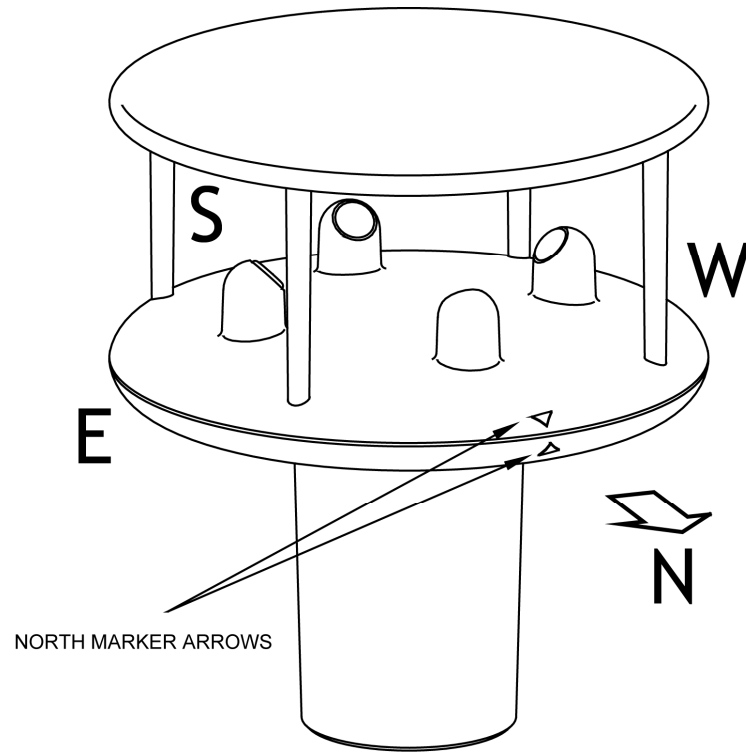

Figure 2 Compass Points

## 5 SPECIFICATION

This Specification relates to WindSonic M Sensors with a 9 way Clipper connector.

<b>Output</b>	
Units of measure	Metres/second (m/s), Knots, Miles per hour (mph), Kilometres per hour (kph), Feet per minute (fpm)
Output frequency	0.25, 0.5, 1, 2, or 4 outputs per second
Digital Output Parameters	Polar - Speed and Direction UV - 2 axis, signed Speed NMEA Speed and Direction Tunnel - U speed & U Polarity
<b>Wind Speed</b>	
Range	0 – 60m/s,
Accuracy	± 2% (at 12m/s)
Resolution	0.01 m/s
<b>Wind Direction</b>	
Range	0 - 359°
Accuracy	± 3° (at 12m/s)
Resolution	1°
<b>Digital output formats</b>	
Gill ASCII	Continuous or Polled (output on request by host system) Polar (Speed and Direction) or UV (2 axis, signed Speed)
Marine – NMEA Tunnel	NMEA 0183 version 3 Tunnel - U speed & U Polarity
<b>Communication formats</b>	
Data Levels	RS232, RS422 and RS485 (2 wire Point to Point only)
Baud Rates	2400, 4800, 9600, 19200, 38400
<b>Anemometer status</b>	Status OK and error codes (not for heating) included in output message
<b>Power requirement</b>	
<b>Sensor Power</b>	Sensor Power 5V to 30 V dc. Sensor Current 9mA @ 12V DC (1Hz, 9600B, RS232). Sensor Current 5.5mA @ 12V DC (0.25Hz, 9600B, RS232).
<b>Heater Power</b>	Heater Power 10V to 30.0V DC. Heater Power 24V rms AC ± 10 % @50/60Hz. Heater Current Allow for 2.2 Amps @ 12V DC nominal supply (26W max.). Heater Current Allow for 4.2 Amps @24v AC or DC nominal Supply (100W max.).
<b>Mechanical</b>	
Size / Weight	Size 142mm diameter x 163mm Weight 0.9kg.
Mounting	Pipe mounting 1.75 inches (44.45mm) diameter.
Material	External – Aluminium Alloy 6061 T6 or T4, hard anodise finish. Connector - Polycarbonate blend.

<b>Environmental</b>	
Moisture protection	IP66
Operating Temperature	Operating -35°C to +70°C Unit without Heating. Operating -40°C to +70°C Unit with Heating.
Storage Temperature	Storage -40°C to +80°C
Humidity	Operating <5% to 100%
Hail	UL2218 Class 1
EMC	EN 61326:1998 and BSEN 60945
<b>Standards</b>	Manufactured within ISO9001: 2000 quality system

## 6 PRE-INSTALLATION

### 6.1 Equipment supplied

Item	Quantity
WindSonic M	1
9 Way connector and Mounting Screws as follows:-	
9 Way Connector Body	1
Connector Contacts	9
Connector Sealing Gland	1
Connector Sealing Washer	1
Mounting Screws – M5 stainless steel	3
Mounting Screw M5 Washer shake proof	3
Earthing Screw – M4 x 6 Stainless	1
Earthing Shakeproof Washer, M4	1
Earthing Ring Terminal Tag, M4	1
User Manual and Wind/WindView software on CD	1

The User Manual, Wind and WindView software are also available free of charge from the Gill website – [www.gillinstruments.com](http://www.gillinstruments.com)

#### 6.1.1 WindSonic M Part Numbers

1405-PK-200 Black WindSonic M –Heating, RS 232 output (default).

1405-PK-300 Black WindSonic M –No Heating, RS 232 output (default).

Optional extras:

Item	Part Number
Cable 4 Pair twisted and shielded wires, 24 AWG, per metre.	026-03156
Cable 3 Pair twisted and shielded wires, 24 AWG, per metre.	026-02660
WindSonic M 9 way connector parts (1 supplied as standard see above)	1405-PK-069
WindSonic M Support Tube, 0.5M (Aluminium)	1405-30-056
15M Cable, 4 Pairs twisted and shielded, 24AWG, clipper pins fitted one end, tinned wires the other.	1405-10-080

## 6.2 Packaging

Whilst the WindSonic M is being moved to its installation site, the unit should be kept in its inner packaging. All the packaging should be retained for use if the unit has to be returned at any time, or if a self-test is performed.

## 6.3 Installation requirements

**Host system** - Use of the following:

- PC fitted with a suitable interface to match the chosen communication format (RS232, RS422, or RS485 point to point only), compatible with the WindSonic M option selected and a suitable Terminal Emulation software package. For example HyperTerminal for Windows.
- Gill Wind software can be used for WindSonic M configuration and is available from the Gill website <http://gillinstruments.com/main/software.html>. It will work on PC's running up to Windows 10.
- Gill WindDisplay (WindSonic M set for RS422 output).
- Other equipment with input/output compatibility to the WindSonic M. For example, Data loggers.

**Cable** - To connect between the WindSonic M and the host system

*See Section 7.3 Cable type for cable specification.*

- There are restrictions on the maximum cable lengths for correct operation.
- The cable should be routed up the inside of the mounting tube.

**Mounting tube**

- Standard tube 1.75 inches (44.45mm) Outside Diameter x 3mm wall thickness. **Note it is important that the correct diameter tube is used**
- See Figure 3 in section 8 Alignment & Mounting Details
- For non-hostile environments, Aluminium tube can be used.
- For hostile environments, you should select a material suitable for the intended environment. For example, stainless steel 316 for marine use.

## 6.4 Cable Assembly

Open the pack of parts provided with the WindSonic M or as 1405-PK-069

Trim back the screened cable outer and screen sleeves 40mm.

Join the screen drain wires together and solder to a single 20-24 AWG insulated wire (for the Chassis Ground connection).

Strip back the connection wires by 5mm and tin solder.

Solder the contact pins to the wires (please note that the connector supplies the correct strain relief for cables with an outside diameter of 6-12mm).

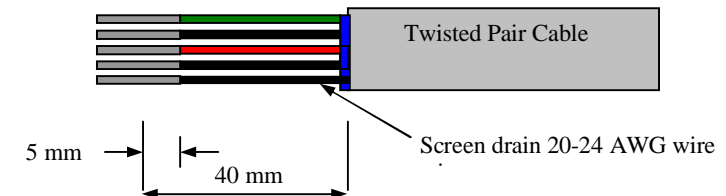

Put the parts on the cable in the order as shown below.



Whilst squeezing the red retainer in the direction of ARROWS A, pull in the direction of ARROW B.



Your connector should now resemble the connector in the picture below.



Insert each contact pin until you feel a slight click. If you have inserted the contact into the incorrect hole it can be removed at this point by simply pulling it out. Please note there will be some resistance.



Rear View of Connector

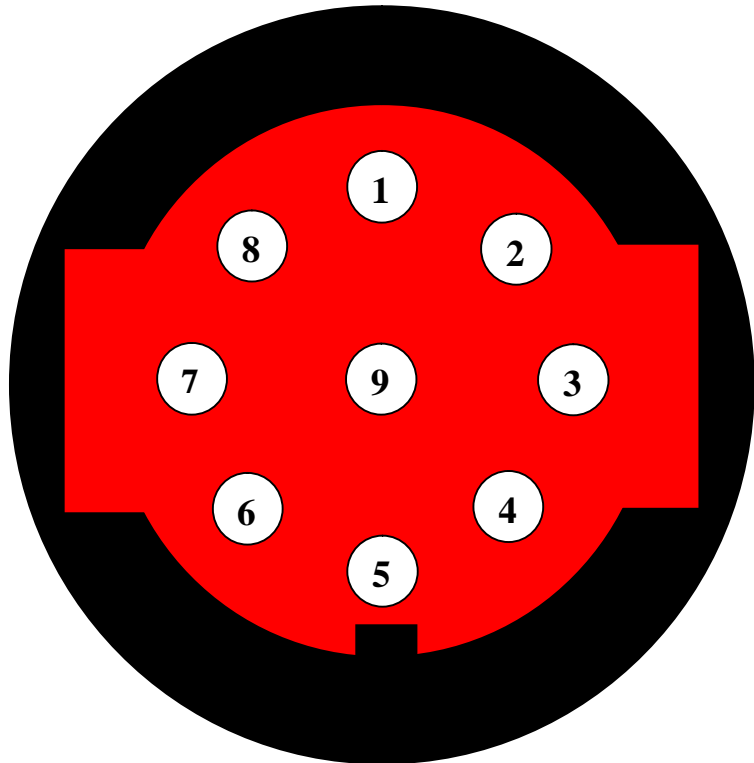

Continue to insert all of the contacts you require. Once all of the contacts are inserted push the red retainer into place. NB. The retainer can only be pushed back into place if the contacts are fully engaged.



Fit the connector to the WindSonic M so that you can finish assembling the connector.



Screw the back shell onto the connector until it is fully in place. Please note that the final rotations can be slightly stiff.



Now screw the next part of the connector into place.



Now screw the cable-clamping nut into place.



The connector can now be removed from the WindSonic M.

**NOTE: To disassemble the connector, reverse this procedure.**

For spares purposes the complete WindSonic Souriau Clipper connector comprises of:-

9 way Connector	CLF1201.
Connector female contact	CM10SS10MQ.
Sealing Gland Clipper size1	CL101021 (suitable for cables 6-12mm outer diameter).

## 7 INSTALLATION

**Do NOT remove the black “rubber” transducer caps. Warranty is void if the coloured security seal is damaged or removed.**

### 7.1 Installation Guidelines

The WindSonic M has been designed to meet and exceed the stringent standards listed in its specification. Operating in diverse environments all over the world, WindSonic M requires no calibration and adjustment whatsoever.

As with any sophisticated electronics, good engineering practice should be followed to ensure correct operation.

- Always check the installation to ensure the WindSonic M is not affected by other equipment operating locally, which may not conform to current standards, e.g. radio/radar transmitters, boat engines, generators etc.

Guidelines –

- Avoid mounting in the plane of any radar scanner – a vertical separation of at least 2m should be achieved.
- Radio transmitting antennas, the following minimum separations (all round) are suggested
  - VHF IMM – 1m
  - MF/HF – 5m
  - Satcom – 5m (avoid likely lines of sight)
- Use cables recommended by Gill. If cables are cut and re-connected incorrectly (perhaps in a junction box) then EMC performance may be compromised if cable screen integrity is not maintained.
- Earth loops should not be created – wire the system in accordance with the installation guidelines.
- Ensure the power supply operates to the WindSonic M specification at all times.

Avoid turbulence caused by surrounding structures that will affect the accuracy of the WindSonic M such as trees, masts and buildings. Ideally sensors should be mounted on the prevailing wind side of the site.

The WMO make the following recommendations:

- The standard exposure of wind instruments over level open terrain is 10m above the ground. Open terrain is defined as an area where the distance between the sensor and any obstruction is at least 10 times the height of the obstruction.

If mounting on a building then theoretically the sensor should be mounted at a height of 1.5 times the height of the building.

If the sensor is to be mounted on a mast boom, part way up a tower or mast, then the boom should be at least twice as long as the minimum diameter or diagonal of the tower. The boom should be positioned on the prevailing wind side of the tower.



## 7.2 Bench system test

**Note: Prior to physically mounting the WindSonic M in its final location, we strongly recommend that a bench system test is carried out to confirm the system is configured correctly, is fully functional and electrically compatible with the selected host system and cabling (preferably utilising the final cable length). The required data format, units, output rate, and other options should also all be set up at this stage.**

## 7.3 Electrical

### 7.3.1 Cable

#### Cable type

An RS422 compatible cable should be used for data communications, with the number of twisted pairs matching the application.

**Generic description** – Twisted pairs with drain wire, screened with aluminised tape, with an overall PVC sheath 6-12mm outer diameter. Wire size 7/0.2mm (20-24 AWG).

The tables below show some suitable manufacturers' references; other manufacturers' equivalents can be used.

#### WindSonic M, Non-Heated

Application	No. of pairs	Gill. 24 AWG	Belden. 24 AWG	Batt electronics. 24 AWG
WindDisplay	2	-	9729	-
RS 232	3	026-02660	9730	91030
RS 422/485	4	026-03156	9728	91199

#### WindSonic M, Heated

Thicker or higher specification cable can be used up to 20 AWG. If long cables are used then consideration should be given to powering the Heater using lower 20 AWG gauge wire or paralleling heater and sensor power cables (24v dc supply only) to reduce volt drops.

Alternatively locate the sensor/heater supply as close as possible to the unit and run data only over the longer cable distances.

Application	No. of pairs	Gill. 24 AWG	Belden. 24 AWG	Batt electronics. 24 AWG
WindDisplay	3	026-02660	9730	91030
RS 232	4	026-03156	9728	91199
RS 422/485	6	026-02661	9731	91031

### Cable length

The maximum cable length is dependent on the chosen communication format (RS232, RS422 or RS485 (point to point)), the baud rate, and, to a lesser extent, on the cable type and the local electrical 'noise' level.

The table shows the typical maximum lengths at the given baud rates, using the recommended cable. If any problems of data corruption etc are experienced, then a slower baud rate should be used. Alternatively, a thicker or higher specification cable can be tried.

For Heater cable lengths advice refer to the previous Cable Type Section.

Communication format	Baud rate	Max. cable length
RS232	9600	6.5 m (20 ft.)
RS422 or 485 (P to P)	9600	1 km (3200 ft.)

### 7.3.2 Power supply

WindSonic M Sensor Supply 5V to 30V DC (30V DC max).

WindSonic M Sensor Current 9mA @ 12V DC (1Hz, 9600B, RS232).

WindSonic M Sensor Current 5.5mA @ 12v DC (0.25Hz, 9600B, RS232).

#### For the Heated WindSonic M variant:-

Heater Power 10V to 30.0V DC.

Heater Power 24V rms AC  $\pm$  10 % @ 50/60Hz.

Heater Current Allow for 2.2 Amps @ 12V DC (nominal supply), 26W max.

Heater Current Allow for 4.2 Amps @ 24v AC or DC (nominal supply) 100W max.

Heater Current Non activated standby current approximately 40mA.

A 24v dc Heater Supply capable of a minimum of 6 Amps is recommended for initial heating start up surge.

Note that the Heater supply is isolated from the Sensor supply.

However it is permissible to connect a common 24v dc supply to both the Sensor supply connections and Heater supply connections if required.

Neither the Sensor supply connections or the Heater supply connections should be connected to the WindSonic M metal case.

Heater Cable length should be minimised to avoid cable volt drops and ensure maximum voltage is received at the Anemometer.

If necessary parallel up spare wires in the cable and connect to the heater pins in order to reduce volt drops.

There is no heating command on the heated WindSonic M, heating is enabled by internal temperature sensing devices and cannot be disabled except by removing the heater supply.

The WindSonic M has reverse polarity protection.

## 7.4 Connecting to a PC using RS232 (Default Sensor)

### Notes.

- Some PCs have a Serial RS232 interface and a suitable terminal emulation package already installed, which can easily be utilised with the WindSonic M. (HyperTerminal or equivalent). Otherwise use Gill Wind Software.
- The cable length for reliable operation is limited to 6.5m (20ft).  
(See Section 7.3.1 Cable length.)
- For longer cable runs, we recommend using the WindSonic M configured with RS422 output, and a RS422/232/USB converter at the PC. See Para 7.8 *Connecting an RS422 output WindSonic M to a PC with an RS422 Interface/Converter.*
- Wiring connections below are not the same as a standard WindSonic Option 1 RS232 unit.**

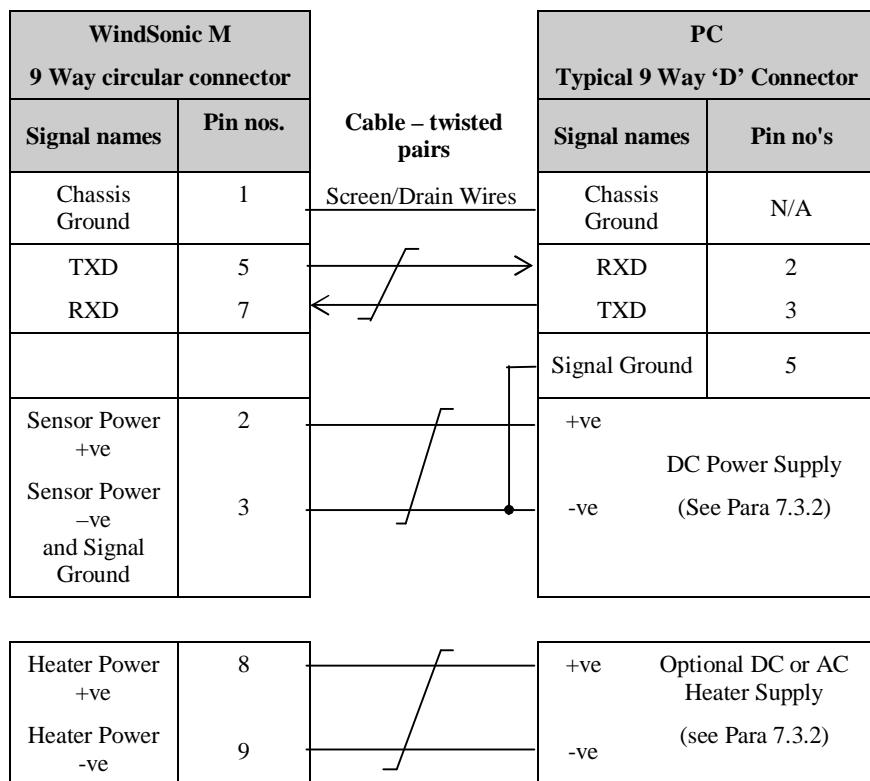

### Default Settings

The WindSonic M unit is factory configured with the following default settings:

**M2, U1, O1, L1, P1, B3, H1, NQ, F1, E3, T1, S4, C2, G0, K50**

## 7.5 Changing a Default Set WindSonic M RS232 Output (Mode E3) to RS422 Output (Mode, E2).

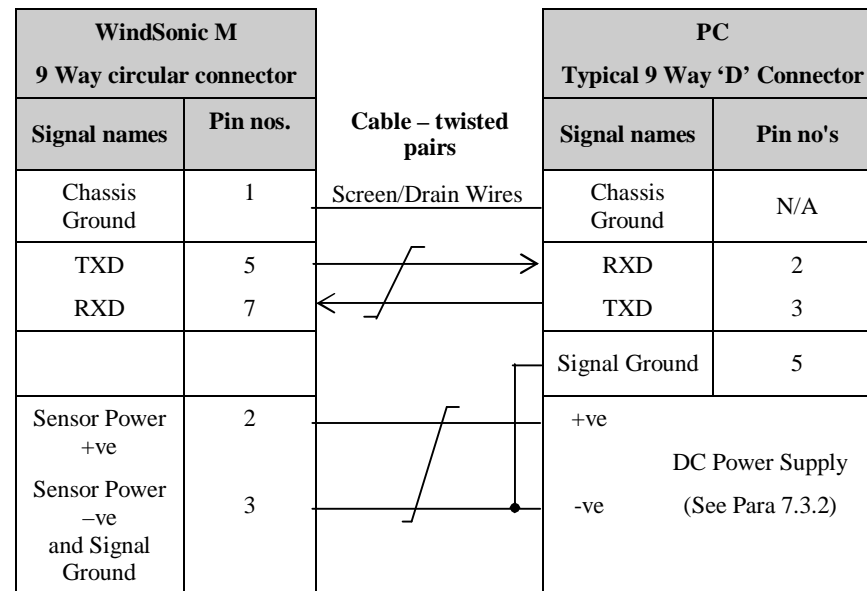

Connect the WindSonic M as per the above diagram.

**Note wiring connections below are not the same as a standard WindSonic Option 1 RS232 unit.**

**With WindSonic M power off**, set up a HyperTerminal connection as per Para 10.3 **but with the Baud rate set to 19200** (this can be at variance with the original WindSonic M Baud rate setting).

**Hold down** the \* character (shift 8) and then apply power to the WindSonic M. After approximately 3 seconds the unit will respond with **Safe Mode**.

Remove any \* characters on screen or press Enter.

Type E2 and press Enter (changes E3 setting to E2 (RS422)).

E2 will be seen twice on screen to confirm the setting change to RS422 has occurred.

It is possible to make other configuration setting changes now if required.

Type Q and press Enter to go back into measurement mode.

Now wire the WindSonic M to an RS422 device.

If a new terminal connection is required the Baud rate setting will be as per the WindSonic M configuration setting.

## 7.6 Using Safe mode to Change an RS422 set Sensor back to RS232 Operation.

Connect the WindSonic M as Para 7.5.

**With WindSonic M power off**, set up a HyperTerminal connection as per Para 10.3 **but with the Baud rate set to 19200 (this can be at variance with the original WindSonic M Baud rate setting)**.

**Hold down** the \* character (shift 8) and then apply power to the WindSonic M. After approximately 3 seconds the unit will respond with **Safe Mode**.

Remove any \* characters on screen or press Enter.

Type E3 and press Enter (changes E2 setting to E3 (RS232)).

E3 will be seen twice on screen to confirm the setting change to RS232 has occurred.

It is possible to make other configuration setting changes now if required.

Type Q and press Enter to go back into measurement mode.

Note garbled data may appear on screen if the original WindSonic M Baud rate setting is not 19200 bauds.

If required close the 19200-baud HyperTerminal connection and re-open at the WindSonic M Baud rate. If a continuous data mode has been previously chosen then data will scroll on screen.

**NOTE Safe Mode above can be used with any WindSonic M for which communication format or configuration settings are not known to obtain communication and change settings.**

## 7.7 Connecting to a Gill WindDisplay

The WindSonic M is designed to link directly to the Gill WindDisplay unit to provide a complete wind speed and direction system.

After coupling to a WindDisplay, the Wind Speed units and the Averaging period can be selected using the WindDisplay controls. See the WindDisplay User Manual.



Meteorological Display



Marine Display

### Important Notes:

1. Set WindSonic M for RS422, (E2 Mode) at 9600 baud for use with the Met Display.
2. If used with a Marine NMEA 4800 Baud WindDisplay set the WindSonic for RS422 Mode (E2) NMEA (M5) and 4800 Baud (B2).
3. Note that although the WindDisplay can display wind speed in various units, these are calculated within the WindDisplay. The data coming to the WindDisplay must be in metres/sec (i.e. the WindSonic M factory default output setting).
4. The WindDisplay can provide power to the WindSonic M sensor.
5. A separate DC or AC power supply is required for WindSonic M heater.

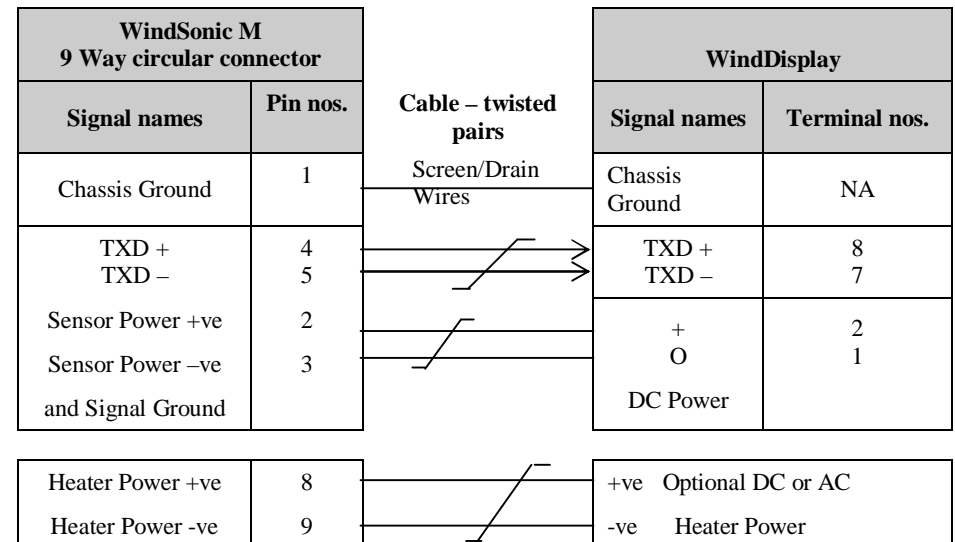

## 7.8 Connecting an RS422 output WindSonic M to a PC with an RS422 Interface/Converter.

### Notes.

WindSonic M must be set for RS422/RS485 mode (E2).

Wiring connections below are not the same as a standard WindSonic Option 2 or 3 unit.

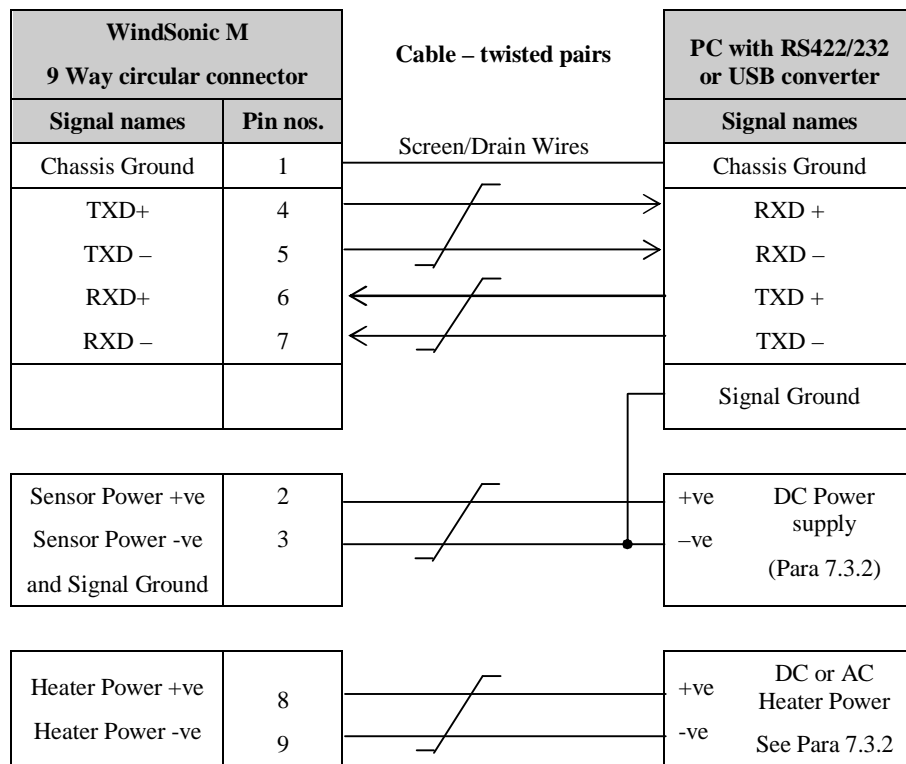

## 7.9 Using 2 Wire RS485 Point to Point Only

### Notes.

- The unit must be set for RS422/485 mode (E2 setting).
- WindSonic M must be set in Polled mode; a node address letter may be given if required.

See Section 9.1 WindSonic M node address.

- Customers may poll using terminal software (NOT supplied).
- Wiring connections below are not the same as a standard WindSonic Option 2 or 3 unit.

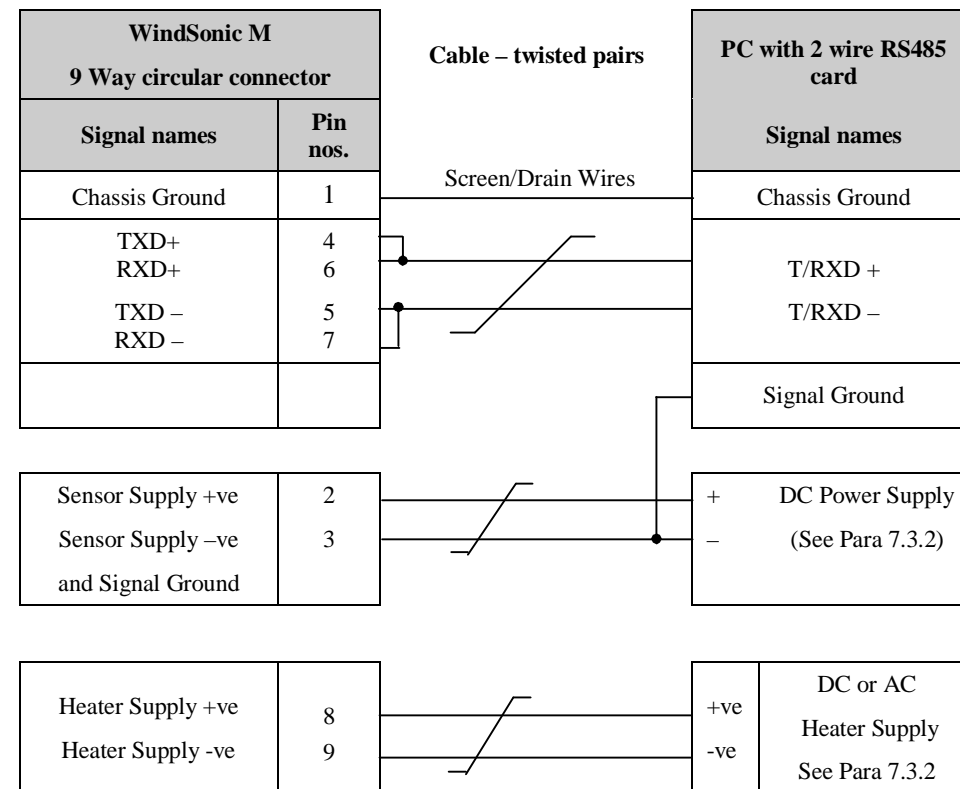

## 7.10 Analogue Output

Analogue Outputs are not available from WindSonic M Sensors 1405-PK-200 and 1405-PK-300.

For Analogue outputs refer to WindSonic M Sensors 1405-PK-201 and 1405-PK-301.

## 8. Mechanical

Before installing, see note at Section 7.2 Bench system test.

### 8.1 Orientation

Normally the WindSonic M is mounted on a vertical tube, ensuring a horizontal Measuring Plane.

See Figure 3 Alignment & Mounting details

For indoor use the unit may be mounted with the Measurement Plane set to any required orientation.

### 8.2 Alignment

The WindSonic M should be aligned to point to North, or any other reference direction –for example, the bow of a boat.

There are three notches aid north alignment.

See Figure 3 Alignment & Mounting Details

**Note:** It is usually simpler to work first with a compass at ground level and identify a suitable landmark and its bearing.

### 8.3 Mounting

The support tube requires three 3 equally spaced holes, tapped M5, 7.5mm from the top of the tube. Pass the cable (fitted with the 9 way Clipper plug) through the tube.

**Note:** the customer must fit appropriate strain relief to the cable.

Connect the plug by twisting it whilst pushing it gently into the socket on the WindSonic M. When it locates, twist the outer sleeve clockwise to connect and lock the plug.

Fix the WindSonic M to the tube using the 3 stainless steel screws provided. (Maximum mounting screw torque 4 Nm.)

It is the responsibility of the customer to ensure that the WindSonic M is mounted in a position clear of any structure, which may obstruct the airflow or induce turbulence.

**Do NOT mount the WindSonic M in close proximity of high-powered radar or radio transmitters. A site survey may be required if there is any doubt about the strength of external electrical noise.**

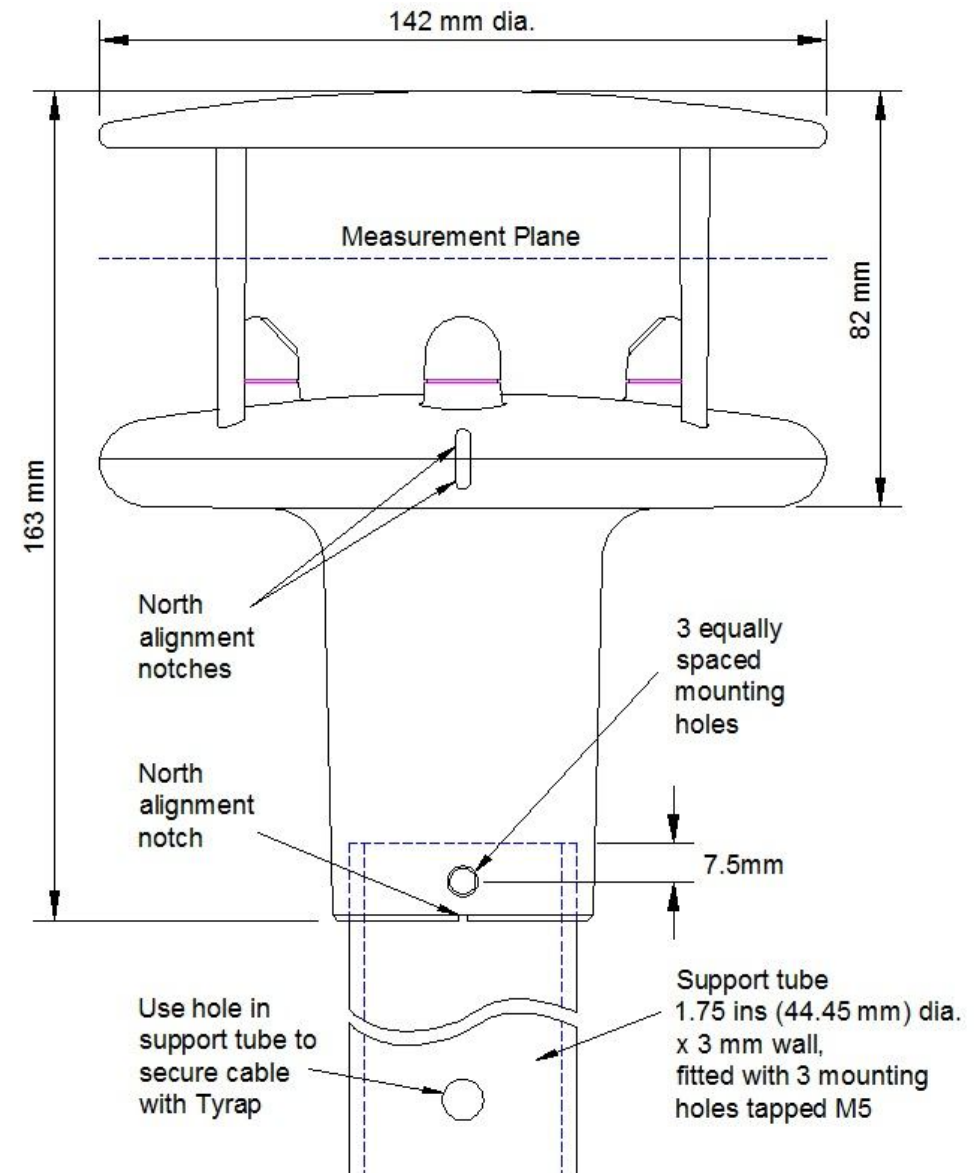

Gill Instruments 0.5 Metre Aluminium support tube can be supplied with drilled and tapped M5 holes as above, part number 1405-30-056.

Figure 3 Alignment & Mounting details

## 8.4 Earthing or Grounding

To ensure correct operation, and for maximum protection against lightning, the anemometer metalwork **MUST** be correctly earthed (grounded) to an appropriate grounding point.

The primary earth for the anemometer must be made using the M4 Earthing Point provided via a minimum of 6mm<sup>2</sup> copper wire to the ground point.

Remove the M4 Nylon screw from the mounting body of the WindSonic M and insert the M4 x 6 Earth Screw/Shakeproof Washer/Ring Terminal lead connection and secure as shown below.

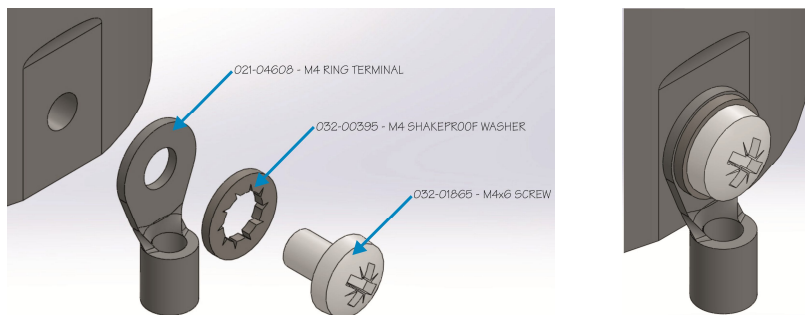

The 3 screws securing the anodised WindSonic M body to a Grounded metal pole/mast cannot be relied on to provide a good ground connection.

Inadequate Earthing/Grounding will degrade anemometer performance, particularly in the presence of radio frequency interference.

If junction boxes are used the cable screens must be joined with any cable screen continuing from the unit's cable via the junction box.

## 8.5 Heating

The WindSonic M can be ordered with Heating (Part 1405-PK-200).

Heating is autonomous and requires no set-up; it is continuously enabled and will operate on and off depending on temperature conditions that are likely to lead to icing.

Heating is first applied to the lower moulding and transducer assemblies, as conditions warrant, it is then applied to the upper reflector plate.

Upon switching on a WindSonic M heated unit, providing heater power is connected then a one minute burst of heating will occur to give confidence that the heating is functioning.

## 9 MESSAGE FORMATS

On applying power to the WindSonic M, it will provide wind measurements in one of the following formats:

- Gill – Polar, Continuous (**default format**)
- Gill - UV, Continuous
- Gill – Polar Polled
- Gill – UV Polled
- NMEA – IIMWV or WIMWV (with NMEA status Codes)
- NMEA - IIMWV or WIMWV (with Gill Status Codes)
- Tunnel – U Direction, U Speed

Each of these is described below.

Information on how to change the formats and settings follows in Section 10 CONFIGURING.

### 9.1 Gill format– Polar, Continuous (Default format)

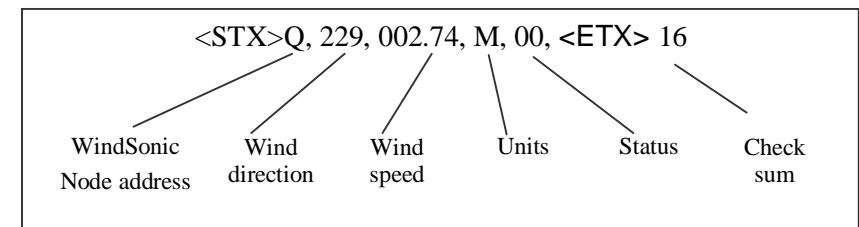

Where:

<STX>	=	Start of string character (ASCII value 2)
WindSonic M node address	=	Unit identifier
Wind direction	=	Wind Direction
Wind speed	=	Wind Speed
Units	=	Units of measure (knots, m/s etc)
Status	=	Anemometer status code ( <i>see Section 11.5 for further details</i> )
<ETX>	=	End of string character (ASCII value 3)
Checksum	=	This is the EXCLUSIVE – OR of the bytes between (and not including) the <STX> and <ETX> characters.
<CR>		ASCII character
<LF>		ASCII character

### WindSonic M node address

The default setting is 'Q'. If required the WindSonic M can be configured to show a different alphabetical node letter (A to Z), so as to identify the WindSonic M.

It is recommended that ID's A to F and K, M, N and P are not used, as these characters can be present in the data string.

### Wind direction

Indicated in degrees, from 0 to 359°, with respect to the WindSonic M North marker.

Whilst the wind speed is below 0.05 metres/sec (K50), then in Comma Separated Variable mode no direction value will be output (e.g. Q,,000.03,M,00,1C). In Fixed Field mode wind direction output will freeze at the last known valid direction value (e.g. Q,133,000.02,M,00,1A) until a new valid value can be calculated.

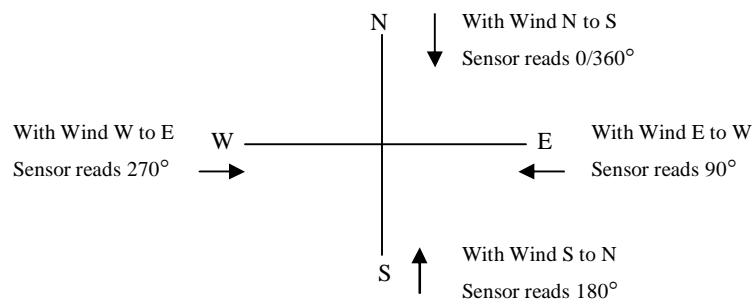

### Wind speed and units

Shows the Wind Speed in the Measurement Plane (See Figure 3 Alignment & Mounting details) in one of the following units:

Units	Identifier
Metres per second (default)	M
Knots	N
Miles per hour	P
Kilometres per hour	K
Feet per minute	F

### Low Wind Speeds (below 0.05m/s)

Whilst the wind speed is below 0.05 metres/sec, the wind direction will not be calculated.

In CSV mode no direction value will be output (e.g. Q,,000.03,M,00,1C). In Fixed Field mode wind direction output will freeze at the last known valid direction value (e.g. Q,133,000.02,M,00,1A) until a new valid value can be calculated.

The above applies with the K command set for K50. If K for instance is set for 100 then the above applies at 0.1m/s.

### Output rate (not displayed)

The WindSonic M samples continuously and delivers wind information at ¼, ½, 1 (default setting), 2, or 4 outputs / second.

### Status

This indicates either

Correct operation Code 00 and A (NMEA).

or Error codes See Section 11.5 for explanation of codes.

### Checksum

This enables the host system to check that the data has been correctly received. This is the EXCLUSIVE – OR of the bytes between (and not including) the <STX> and <ETX> characters.

## 9.2 Gill format – UV, Continuous

In this mode, the output is given as signed (i.e. positive or negative) speeds along the ‘U’ (= South – North) axis and the ‘V’ (= East – West) axis.

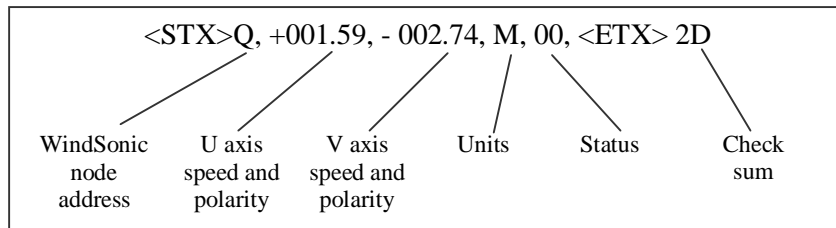

Where:

<STX>	=	Start of string character (ASCII value 2)
WindSonic M node address	=	Unit identifier
U axis	=	speed & polarity
V axis	=	speed & polarity
Units	=	Units of measure (knots, m/s etc.)
Status	=	Anemometer status code ( <i>see Section 11.5 for further details</i> )
<ETX>	=	End of string character (ASCII value 3)
Checksum	=	This is the EXCLUSIVE – OR of the bytes between (and not including) the <STX> and <ETX> characters

The WindSonic M unit identifier, Units, and Checksum are as described in Section 0 above.

Figure 5 shows the polarity of U and V if the wind components along the U and V axis are blowing in the direction of the respective arrows.

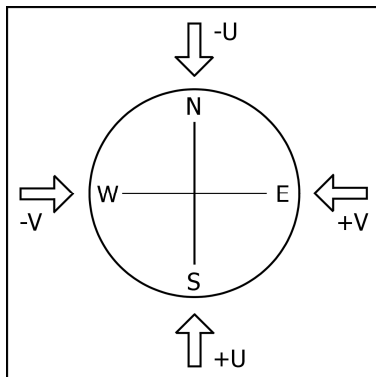

Figure 5 UV Polarity

## 9.3 Gill format – Polled (Polar or UV)

When in the Polled mode, an output is only generated when the host system sends a Poll signal to the WindSonic M consisting of the WindSonic M Unit Identifier – that is, the relevant letter A – Z.

The output formats are otherwise as described in Sections 9.1 and 9.2.

The commands available in this mode are:

Description	Command	WindSonic M response
WindSonic M Unit Identifier	A ..... Z	Wind speed output generated
Enable Polled mode	?	(None)
Disable Polled mode	!	(None)
Request WindSonic M Unit Identifier	? &	A ..... Z (as configured)
Enter Configuration mode	? * <N>	CONFIGURATION MODE

Where <N> is the unit identifier, it is recommended that ID's A to F and K,M,N, or P are not used as these characters can be present in the data string.

Notes: -

It is suggested that in polled mode the following sequence is used for every poll for information.

? Ensures that the Sensor is enabled to cover the event that a power down has occurred.

A-Z Appropriate unit designator sent to retrieve a line of data.

! Sent to disable poll mode and reduce possibility of erroneous poll generation.

When in polled mode the system will respond to the data command within 130mS with the last valid data sample as calculated by the Output rate (P Mode Setting).

If the unit is powered down after use or upon switch on then allow 5 seconds from switch on before sending poll commands.

Polled mode can only be used for point to point communications, it is not possible to network units on a common bus.



### 9.4 NMEA Format (NMEA status Codes)

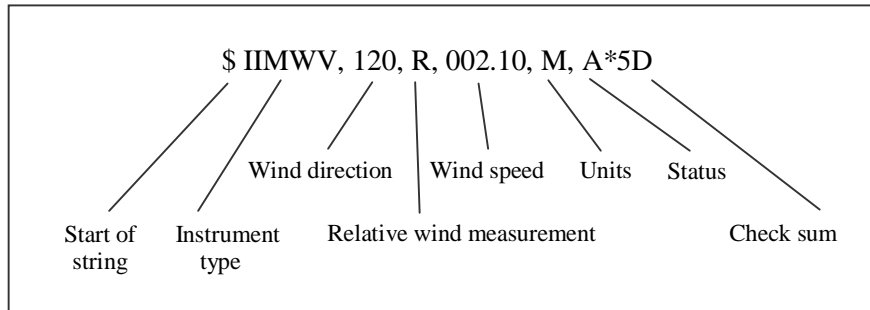

The **Wind Direction**, **Wind Speed**, and **Units** are as described in Section 9.1.

The **Instrument Type** – IIMWV - is a mnemonic for Integrated Instrument Mean Wind direction & Velocity.

The **Status** codes are:

- A Acceptable measurement
- V Void measurement

A typical WindSonic M configuration suitable for NMEA:

M5, U1, O1, L1, P1, B2, H1, NQ, F1, E2, T1, S4, C2, G0, K50

Consult specification NMEA 0183 version 3 (available on the web) for complete interface details.

The WindSonic M can also be set for the alternative start of string NMEA format WIMWV (Mode 14, which is a Mnemonic for: -

Wind Instrument Mean Wind direction and Velocity.

The string format will appear as above but with WIMWV at the start of the string.

### 9.5 NMEA Format (Gill status Codes)

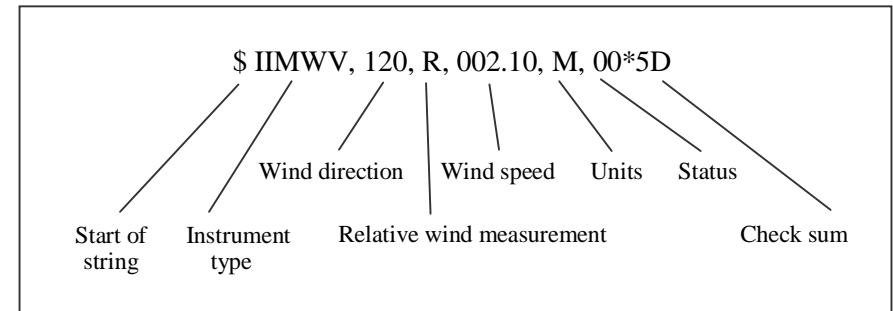

The **Wind Direction**, **Wind Speed**, and **Units** are as described in Section 9.1.

The **Instrument Type** – IIMWV - is a mnemonic for Integrated Instrument Mean Wind direction & Velocity (alternative start of string format WIMWV can be selected).

The **Gill Status** codes are as described in Para 11.5.

A typical WindSonic M configuration suitable for NMEA:

M16, U1, O1, L1, P1, B3, H1, NQ, F1, E2, T1, S4, C2, G0, K50

Consult specification NMEA 0183 version 3 (available on the web) for complete interface details.

### 9.6 Gill format – Tunnel Mode (UU, Continuous)

In this mode, the Wind Speed output is given as a signed figure (i.e. positive or negative) along the 'U' (= South – North) axis.

Direction is indicated by a 0 or 1.

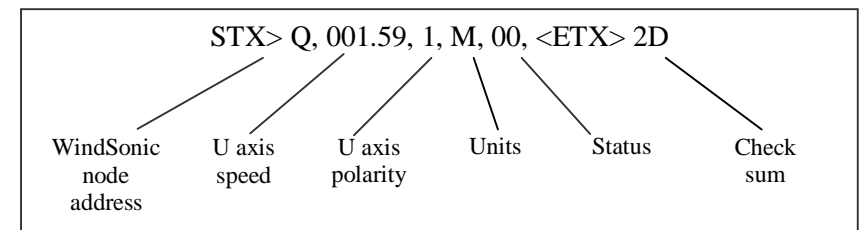

Where:

- `<STX>` = Start of string character (ASCII value 2)
- WindSonic M node address = Unit identifier
- U axis = U axis Wind Speed
- U axis = U axis Wind Direction Polarity where: -
  - 0 (-U vector) is a wind from the North direction or
  - 1 (+U vector) is a wind from the South direction.

See Section 9.1 for other string information.

## 9.7 Analogue Outputs and Options

**Note: Analogue outputs are not available from the WindSonic M.**

### 9.7.1 Low wind speeds (below 0.05 m/s).

Whilst the wind speed is below 0.05 metres/sec, the wind direction will not be calculated. In both CSV mode and in Fixed Field mode, Channel 2 wind direction output will freeze at the last known valid direction value until a new valid value can be calculated.

The above applies with the K command set for K50. If K for instance is set for 100 then the above applies at 0.1m/s.

## 10 CONFIGURING

Wind may be used to configure the WindSonic M; alternatively, the user may elect to use another terminal emulator package such as Windows HyperTerminal. This section describes the commands used to change User and Communications settings.

### 10.1 Wind

Wind software is available on the supplied CD or to download, free of charge, from the Gill Instruments Limited website. <http://gillinstruments.com/main/software.html>.

Wind software allows the unit configuration to be changed and to be able to display the Digital Data String on a PC screen.

Connect both WindSonic M transmit and receive data lines to the PC to establish 2 way communications.

Open Wind Software and select the appropriate Com Port from the drop down menu and click on OK to reach the data screen.



If data is not correctly displayed then on the Menu click on Tools/Synch Comms.

The Sensor will be interrogated and Sensor Baud Rate and Mode settings detected and reported.

Wind software settings will be adjusted to match those of the sensor to show data scrolling on screen.

If after Synch Comms there is still a problem, repeat Synch Comms or switch off the sensor and switch back on again and repeat above procedure.

**Note: - It is also possible to use Wind as a Terminal Program and change settings using the Configuration Mode of operation (Commands are listed in Para 10.7.1).**

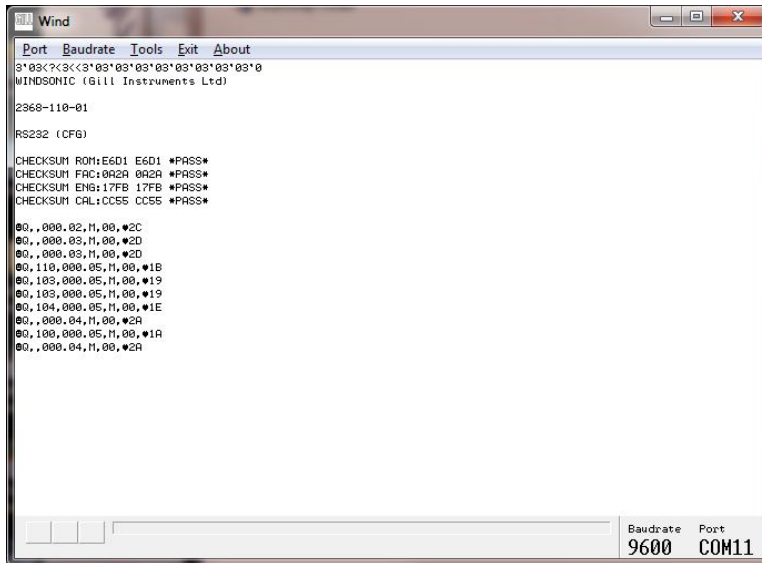

If you wish to review the Sensor Settings click on **Tools/Report Config**.  
When selected a similar message to that below will be seen.

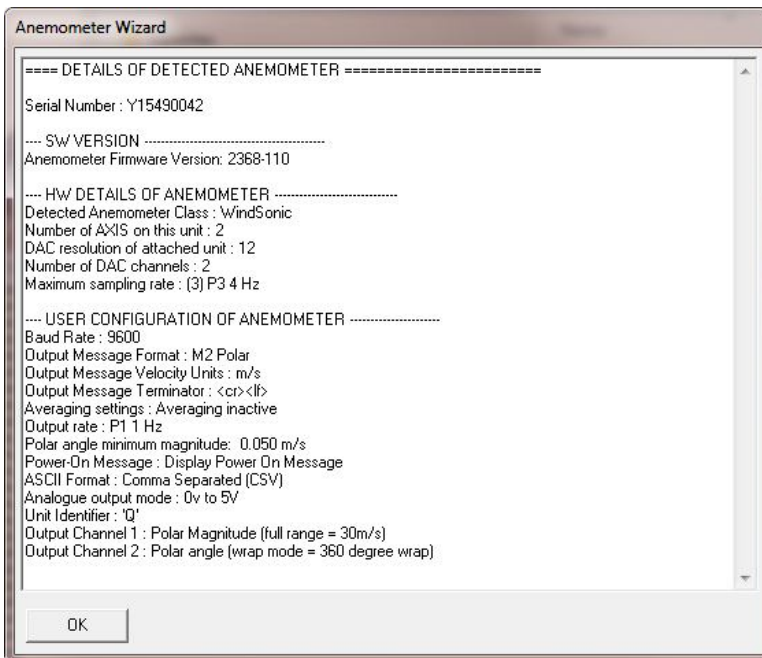

To review and change the WindSonic M configuration click on **Tools/Wizard**  
Typical Screen is shown following

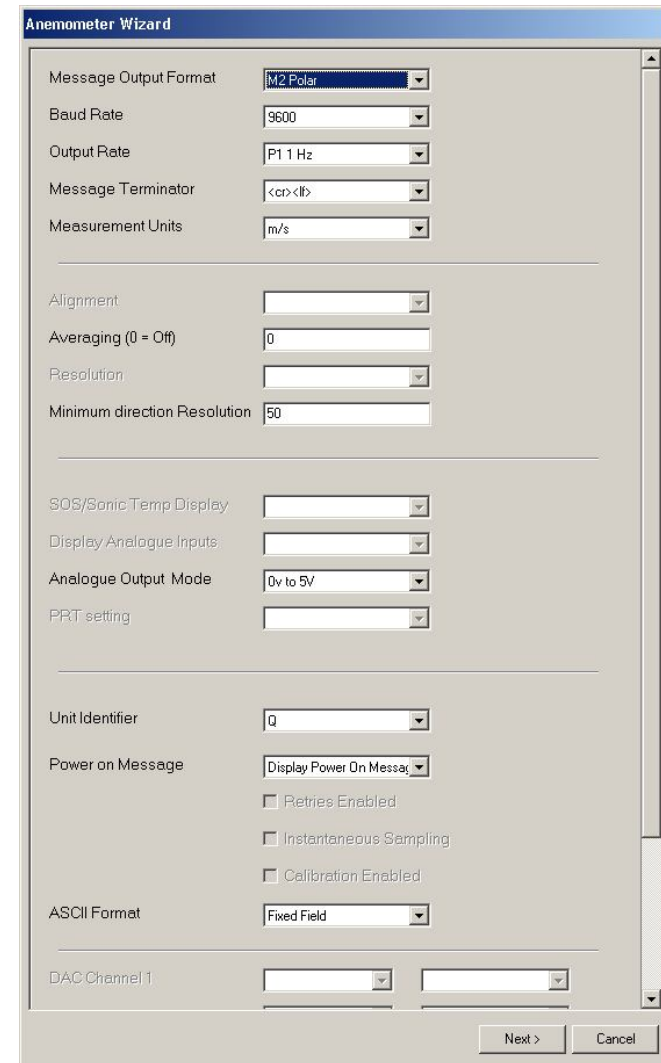

To change a setting i.e. change from M2 (Polar) to M1 (UV), select M1 from the Wizard drop down list then click on Next.

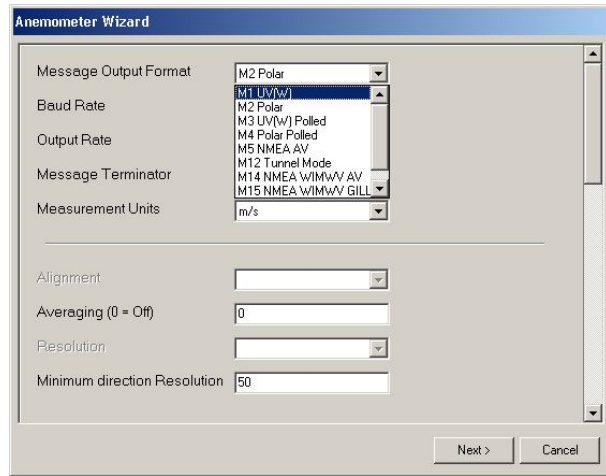

The following screen will show settings that will be changed. Then click on Next.



Wind will report Setting Up Anemometer and then re-start the anemometer scrolling data in UV mode.

## 10.2 WindView

WindView software is available for the customer to download as above, free of charge from the Gill Instruments Limited website <http://gillinstruments.com/main/software.html>.

WindView features include: -

- Data Display
- Data Logging

**NOTES:**

*WindView cannot be used to change the WindSonic M configuration.*

Open Gill WindView software program.

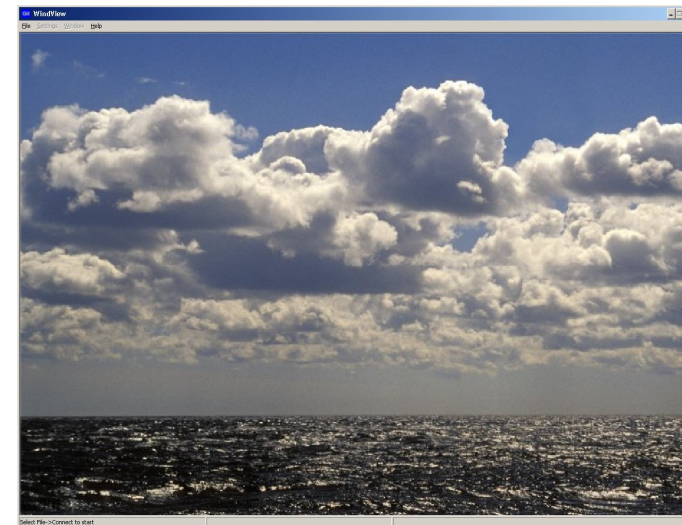

Select File/Connect as follows:-



Select the required COM Port from the drop down list.

Select the required Baud rate from the drop down list.

Parity should be set to None.

If the Baud rate setting of the Anemometer is unknown then the Auto Find button can be used to interrogate the Anemometer and detect the required setting.

Click on the Connect button.

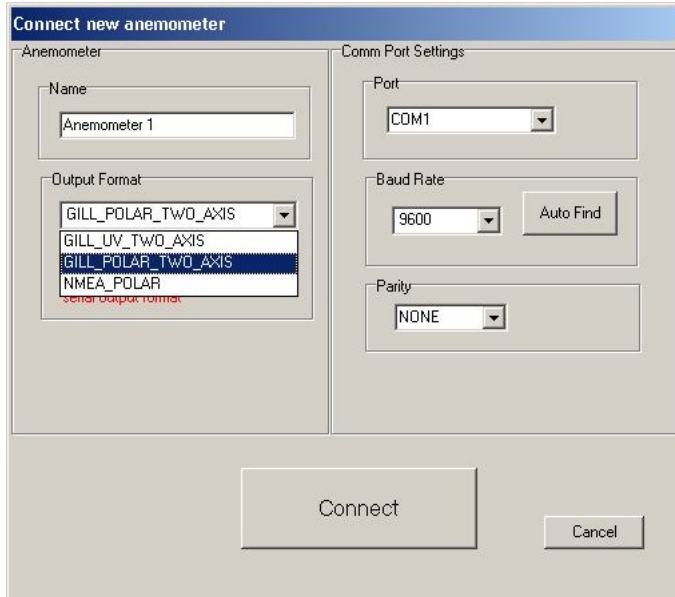

Data should scroll on the screen as follows (Data button).

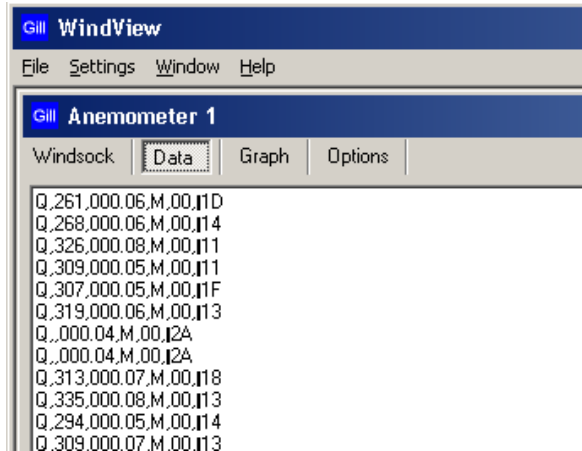

Clicking on the Anemometer 1 Windsock button gives the following display.

To Change WindView Display Settings

Click on the top of Screen menu Settings.

To change displayed units select and click on required measurement units. If for instance the sensor data was outputting metres per second data then WindView performs the calculation to convert and display the output in knots/mph/kph etc.

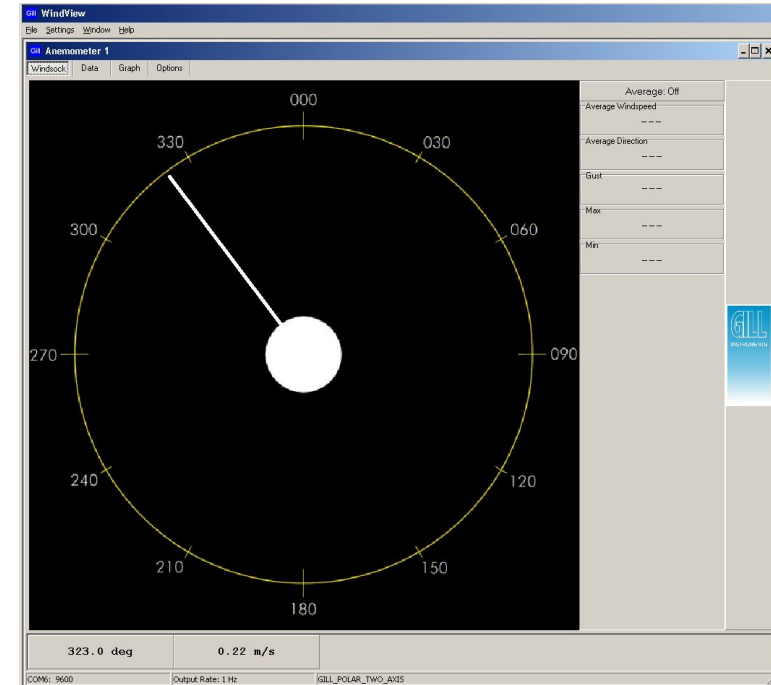

For Logging Facilities.

Click on Settings/Logging to reach the logging screen.

If segmented logging is required this will create and save individual files of length set by the figure in the mins box. Otherwise a continuous log file will be recorded.

Select required Directory for saved file and File name.

Click on Apply.

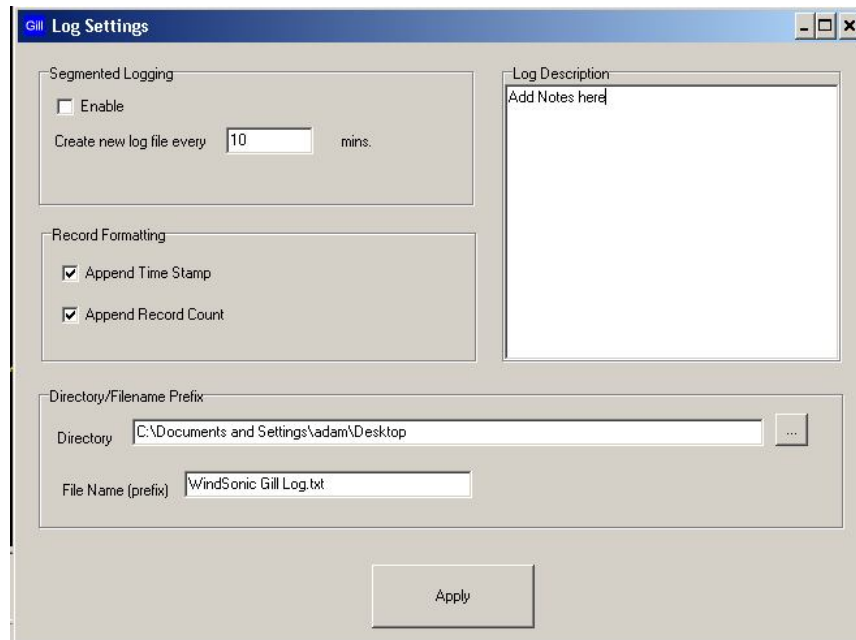

Click on the Note OK button.

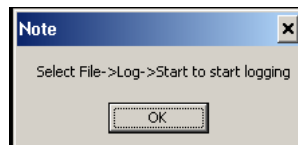

To Start Logging select File/Log/Start.

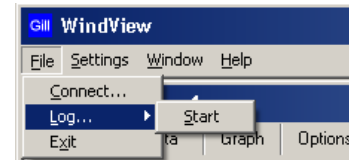

To Stop logging select File/Log/Stop.

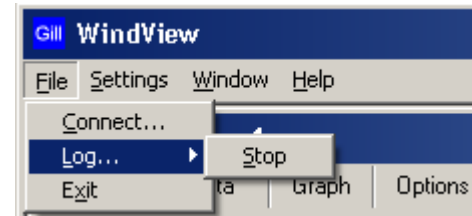

Example saved data opened in Notepad.

```
File Edit Format View Help
WindView Log File
Add Notes here
WindSonic log test
Name: Anemometer 1
Output Format: GILL_POLAR_TWO_AXIS
Log file opened: 13/06/2008 10:50:09

Q,322,000.22,M,00,01D,1,13/06/2008 10:50:10
Q,307,000.22,M,00,01A,2,13/06/2008 10:50:11
Q,342,000.28,M,00,011,3,13/06/2008 10:50:12
Q,320,000.29,M,00,014,4,13/06/2008 10:50:13
Q,340,000.12,M,00,01A,5,13/06/2008 10:50:14
Q,312,000.21,M,00,01D,6,13/06/2008 10:50:15
Q,318,000.37,M,00,01D,7,13/06/2008 10:50:16
Q,321,000.26,M,00,01A,8,13/06/2008 10:50:17
Q,291,000.19,M,00,01C,9,13/06/2008 10:50:18
Q,312,000.14,M,00,01B,10,13/06/2008 10:50:19
Q,314,000.20,M,00,01A,11,13/06/2008 10:50:20
```

## 10.3 Configuring using HyperTerminal

**Note** – Other terminal emulators are configured in a very similar way.

1. Decide on an available Com port that you want to use (Usually Com1).
2. Run Hypertrm.exe (Typically accessed via Start → All Programs → Accessories → Communications → Hyperterminal).
3. Create a New Connection (File → New Connection)
4. Enter a **Name** (eg WindSonic M 1).
5. Change '**Connect Using**' to 'Direct to Com 1' (or other Com port as required)
6. Adjust the Port settings to match WindSonic M settings. WindSonic M default settings are :

**Bits per second** 9600

**Data bits** 8

**Parity** None

**Stop bits** 1

**Flow Control** (Handshaking) None

Click on OK and data similar to the following example will scroll on screen at the output rate:

```
☺ Q, 229, 002.74, M, 00, ♥ 06
```

## 10.4 Entering Configuration mode

**From Continuous mode**

Type **\***

**From Polled mode**

Type **\*** then **<N>**

Where <N> is the Unit identifier

The WindSonic M responds with a CONFIGURATION MODE message, stops reporting wind measurements, and waits for a command (as detailed below).

## 10.5 Returning to Measurement mode

Type **Q** then press **ENTER**

The WindSonic M responds with a checksum test and then continuous wind information when in continuous mode, or on receipt of a Poll signal when in Polled mode.

## 10.6 Checking the configuration

We recommend that, as a standard procedure, you use this command prior to, and after, changing any settings. It shows the current settings for all the alterable settings.

Type **M**

Type **D** **3** then press **ENTER**

The WindSonic M responds with the default settings.

```
M2, U1, O1, L1, P1, B3, H1, NQ, F1, E3, T1, S4, C2, G0, K50
```

We suggest you note down the settings, so that you can easily return to them.

Return to measurement mode

Type **Q** then press **ENTER**

All of these settings are explained in the following sections.

## 10.7 Changing a setting

To change a setting, refer to the sections below, enter the command of the new setting required, followed by **ENTER**. The new setting will be sent as a message by the WindSonic M.

For example, to change the message format to NMEA, Type **M** **5** and press **ENTER**

The WindSonic M will reply **M5**. When the unit is returned to the Measurement mode, it will be in NMEA format.

### Notes:

The factory-set (default) settings are shown in **bold** in the following sections.

To Change E Command setting refer to **Safe Mode** operation, Para's 7.5 and 7.6.

## 10.7.1 Command List

COMMAND	USER
<b>B</b>	<b>Baud rate</b>
<b>C</b>	<b>Analogue angle wrapping</b>
<b>D</b>	<b>Diagnostic and Configuration</b>
<b>E</b>	<b>Set Physical Comms</b>
<b>F</b>	<b>Data and Parity Options</b>
<b>G</b>	<b>Not currently used</b>
<b>H</b>	<b>Power-Up message</b>
<b>K</b>	<b>Minimum Direction Velocity</b>
<b>L</b>	<b>Message Terminator</b>
<b>M</b>	<b>Message Format</b>
<b>N</b>	<b>Unit ID</b>
<b>O</b>	<b>ASCII Output format</b>
<b>P</b>	<b>Output rate</b>
<b>Q</b>	<b>MEASUREMENT MODE</b>
<b>S</b>	<b>Analogue output range</b>
<b>T</b>	<b>Analogue output type</b>
<b>U</b>	<b>Select Units</b>
<b>*</b>	<b>INTERACTIVE MODE</b>

## Bx - Baud rate

Item	Options	Command
<b>Baud rate</b>	2400	B1
	4800	B2
	<b>9600</b>	<b>B3</b>
	19200	B4
	38400	B5
<p>To change the Baud rate when using HyperTerminal: -</p> <p>Eg. If set to B3 (9600 baud) and it is required to set to Baud rate to B2 (4800 baud).</p> <p>Type <b>**</b> to enter Configuration Mode.</p> <p>Type <b>B 2</b> and press <b>ENTER</b>, (<b>Do not type any further commands at this stage</b>).</p> <p>Close the 9600 Baud HyperTerminal connection.</p> <p>Open HyperTerminal and set the new connection Baud Rate to 4800 baud.</p> <p>Type <b>B</b> and press <b>ENTER</b>, the letter B will be shown followed by Capitol B2</p> <p>Type <b>Q</b> and press <b>ENTER</b>, data will scroll at the new baud rate.</p>		

## Cx - settings

Not Applicable.

## Dx - Diagnostic and Configuration Command (See Section 10.8)

## Ex - Communications Protocol

Item	Options	Command
Communications protocol	RS422 / RS485	E2
	<b>RS232</b>	<b>E3</b>
To change settings refer to Connecting to a PC (Para's 7.5 and 7.6).		

## Fx - Data and parity options

Item	Options	Command
<b>Data and parity options</b>	<b>8 bits, no parity</b>	<b>F1</b>
	8 bits, even parity	F2
	8 bits, odd parity	F3



## Gx - settings

Not Applicable

## Hx - Power-up Message

Item	Options	Command
Power –up message	ON OFF	H1 H2
<p>If the power up message is On, then a message similar to that below is output, whenever the unit goes into Measurement mode (i.e. when power is first applied to the unit, or unit returns to Measurement mode from Configuration mode).</p> <p>WINDSONIC M (Gill Instruments Ltd) 2368-110-01 RS485/RS422 (CFG) CHECKSUM ROM:E15C E15C *PASS* CHECKSUM FAC:0A42 0A42 *PASS* CHECKSUM ENG:12BE 12BE *PASS* CHECKSUM CAL:C980 C980 *PASS*</p> <p>If any of these checksums fail, the word PASS will be replaced by FAIL and the unit will use its default settings. If the checksum repeatedly fails after power on – contact your supplier.</p> <p><b>NOTE:</b> The exact message above may vary.</p>		

## Kxx to Kxxxx - Minimum Direction Velocity

Item	Options	Command
Minimum Direction Velocity	0.05m/s to 5m/s	K50 KXX to KXXXX
<p>This feature allows the minimum wind velocity to be set at which display of the direction is enabled in thousandth of a metre per second. The default is 50, which means that any wind magnitude less than 0.05m/s will have the wind direction omitted in Comma Separated Variable mode.</p> <p>E.g. Q,,000.04,M,3C.</p> <p>Or last wind reading at 0.05m/s or above repeated in Fixed Field Mode.</p> <p>E.g. Q,237,000.04,M,3C.</p>		

## Lx - Message Terminator

Item	Options	Command
Message terminator	<CR> <LF> <CR>	L1 L2

## Mx to Mxx - Message Format

Item	Options	Command
Message Format	Gill, UV, Continuous	M1
	<b>Gill, Polar, Continuous</b>	<b>M2</b>
	Gill, UV, Polled	M3
	Gill, Polar, Polled	M4
	NMEA, IIMWV (NMEA status code)	M5
	Tunnel Continuous	M12
	NMEA, WIMWV (NMEA status code)	M14
	NMEA, WIMWV (Gill status code)	M15
	NMEA, IIMWV (Gill status code)	M16

## Nx - Node Address

Item	Options	Command
Node Address	Q... -(A to Z)	N<Q>

It is recommended that ID's A to F and K, M, N and P are not used, as these characters can be present in the data string.

**Ox - ASCII Output Format**

Item	Options	Command
ASCII output format	Comma separated format (CSV)	O1
	Fixed field	O2

Example data string for CSV data changing to low wind less than 0.05m/s (set for K50) and error status code condition.

⌈ Q,156,000.05,M,00,⌋ 19

⌈ Q,,000.04,M,00,⌋ 2A (low wind, no direction figure output at 0.04m/s or lower).

⌈ Q,100,000.09,M,00,⌋ 16

⌈ Q,,M,04,⌋ 24 (error data, no figures output in wind fields).

Example data string for Fixed Field data changing to low wind less than 0.05m/s (set for K50) and error status code condition.

⌈ Q,160,000.05,M,00,⌋ 1C

⌈ Q,160,000.04,M,00,⌋ 1D (low wind, last direction figure at 0.05m/s or above retained).

⌈ Q,170,000.06,M,00,⌋ 1E

⌈ Q,999,999.99,M,04,⌋ 0A (error data, wind fields padded with 9's).

**Px to Pxx - Output Rate**

Item	Options	Command
Output rate	1 per second	P1
	2 per second	P2
	4 per second	P3
	1/4 per second	P20
	1/2 per second	P21

**Q - Measurement Mode**

See Section 10.5.

**Sx - Settings**

Not Applicable.

**Tx – Settings**

Not Applicable.

**Ux - Output Units**

Item	Options	Command
Output Units	Metres per second (M)	U1
	Knots (N)	U2
	Miles per hour (P)	U3
	Kilometres per hour (K)	U4
	Feet per minute (F)	U5

## 10.8 Configuration / Diagnostic Information

Each of these commands causes a response from the WindSonic M.

Item	Command	Response
Type and serial No.	D1	Y16120001
Software version	D2	2368-110-01
Unit configuration	D3	M2,U1,O1,L1,P1,B3,H1,NQ,F1,E3,T1,S4,C2,G0,K50,
Supply Voltage	D5	+11.7v
Self test	D6	<p><i>See Section 12.2 Self-Test (Still Air)</i></p> <p>ALIGNMENT LIMITS:0D59,0CF5</p> <p>ALIGNMENT U:0D15 *PASS*</p> <p>ALIGNMENT V:0D16 *PASS*</p> <p>CHECKSUM ROM:AB7D AB7D *PASS*</p> <p>CHECKSUM FAC:04F4 04F4 *PASS*</p> <p>CHECKSUM ENG:082A 082A *PASS*</p> <p>CHECKSUM CAL:A9C1 A9C1 *PASS*</p>
Hardware Configuration	D10	<p>Serial Number : Y16120001</p> <p>Software Version : 2368-110-01</p> <p>Class : WINDSONIC (Gill Instruments Ltd)</p> <p>Number of axes on this unit : 2</p> <p>Axes tilted 45deg to horizontal plane</p> <p>No Analogue Outputs</p> <p>Maximum output rate: 004Hz</p> <p>Maximum base rate on this unit is 16Hz sampling</p> <p>Available baudrates: 002400 004800 009600 019200 038400</p> <p>Available messages: M1 M2 M3 M4 M5 M12 M14 M15 M16</p> <p>Safe mode enabled</p> <p>Parity control allowed: F1 F2 F3</p> <p>Communication modes: RS232 RS485/422</p>

## 11 MAINTENANCE & FAULT-FINDING

### 11.1 Cleaning

If there is any build up of deposit on the unit, it should be gently cleaned with a cloth moistened with soft detergent. Solvents should not be used, and care should be taken to avoid scratching any surfaces. The unit must be allowed to defrost naturally after being exposed to snow or icy conditions, do NOT attempt to remove ice or snow with a tool.

**Do NOT remove black “rubber” transducer caps.**

### 11.2 Servicing

There are no moving parts or user-serviceable parts requiring routine maintenance.

Opening the unit or breaking the security seal will void the warranty and the calibration.

In the event of failure, prior to returning the unit to your authorised Gill distributor, it is recommended that:

1. All cables and connectors are checked for continuity, bad contacts, corrosion etc.
2. A bench test is carried out as described in Section 11.1.
3. You contact your supplier for advice

### 11.3 Fault Finding

Symptom	Solution
No output	<p>Check DC power to WindSonic M, cable and connections.</p> <p>Check comms settings of WindSonic M (<i>as detailed in Section 10</i>) and host system match, including correct Com port</p> <p>Check unit is in Continuous mode</p> <p>Check that in-line communication devices are wired correctly.</p> <p>NOTE: It is usual for Anemometer TX + to be connected to converter device RX +</p>
Corrupted output	<p>Check comms settings of WindSonic M and host system match.</p> <p>Try a slower baud rate.</p> <p>Check cable lengths and type of cable.</p>
One way communication	<p>Check WindSonic M and host system are both set to the same protocol RS232, RS422, or RS485.</p> <p>Check wiring is in accordance with the manual.</p>
Failed / Incorrect WindSonic M output, data invalid flag	<p>Check that transducer path is not blocked</p>

## 11.4 Returning Unit

If the unit has to be returned, it should be carefully packed in the original packaging and returned to your authorised Gill distributor, with a full description of the fault condition.

## 11.5 Status

The Status code is sent as part of each wind measurement message.

Note there are no heating on/off or fault status codes.

Code	Status	Condition
00	OK	Sufficient samples in average period
01	Axis 1 failed	Insufficient samples in average period on U axis
02	Axis 2 failed	Insufficient samples in average period on V axis
04	Axis 1 and 2 failed	Insufficient samples in average period on both axes
08	NVM error	NVM checksum failed
09	ROM error	ROM checksum failed
A	-	NMEA data Acceptable
V	-	NMEA data Void

## 12 TESTS

### 12.1 Bench test

#### Data Tests.

1. Couple the WindSonic M to the host system and power supply, using a known working test cable.
2. Check that the unit is correctly configured by going into Configuration mode and using **[D]** See Section 10.6 Checking the configuration.
3. Check for normal output data, and that the Status Code is OK – 00 (or A for NMEA format).
4. If the status code is other than 00 or A, refer to Section 11.5 Status (error) codes.
5. Use an office fan or similar to check that the unit is sensing wind, turning the unit to simulate changing wind direction and to check that both axes are functioning.
6. Note that this is a quick functional test. There are no calibration adjustments; the unit is designed NOT to require re-calibration within its lifetime.

#### Heater Tests (if applicable).

1. Connect the WindSonic M Heater wires to a 24v dc power supply.
2. Switch on the heater Power Supply and observe that heater current is drawn and is greater than 2.5 amps.
3. Heating current will be taken for approximately 60 seconds, check that the underneath of the top reflector plate has warmed up and the top of the transducer mounting assembly has warmed up.

## 12.2 Self-Test (Still Air)

This test checks Alignment and Checksums.

**Alignment tests:** The unit performs a transducer geometry check and compares the result with its factory setting.

**Checksum tests:** The unit performs a check of its program and data memory.

**Important.** *This test is a stringent laboratory test, which will only be passed if carried out under still air conditions at room temperature (17-23°C) and heating not powered.*

1. Use the original packing box (inner and outer) to enclose the unit. (The packaging is designed as a zero wind enclosure).
2. Go into Configuration Mode **[\*]** **[ENTER]** .
3. Carry out the Self-test by entering **[D]** **[6]** **[ENTER]** .

A message similar to that shown below will be generated:

```
ALIGNMENT LIMITS:0D59,0CF5
ALIGNMENT U:OD15 *PASS*
ALIGNMENT V:OD16 *PASS*
CHECKSUM ROM:AB7D AB7D *PASS*
CHECKSUM FAC:04F4 04F4 *PASS*
CHECKSUM ENG:082A 082A *PASS*
CHECKSUM CAL:A9C1 A9C1 *PASS*
```

For each of the Alignment tests a Pass or Refer to Manual message is generated.

For each of the Checksum tests a Pass or Fail message is generated.

4. If any of the tests fail, contact your supplier.

If a “refer to manual” message appears please see Section 11.3 Fault Finding.

**Note that it will only pass if the specified temperature and zero wind conditions are met.**

Check that there are no visible obstructions or damage to the unit before contacting Gill or your authorised distributor for further advice.

## 12.3 Calibration

A Custom calibration is available from Gill Instruments. This must be specified at the time of order or the unit must be returned to Gill Instruments for retrospective calibration.

## 13 APPENDICES

### 13.1 Glossary & Abbreviations

Item	Meaning
CAL	Calibration
CR	Carriage Return
CSV	Comma Separated Variable
ENG	Engineering
FAC	Factory
KPH	Kilometres per Hour
LF	Line Feed
MPH	Miles per Hour
NMEA 0183 (version 3)	National Marine Electronics Association standard for interfacing marine electronic navigational devices
NVM	Non-Volatile Memory
PC	IBM compatible Personal Computer
ROM	Read Only Memory
RS232	Communications standard
RS422	Communications standard
RS485	Communications standard
RXD	Received Data
TXD	Transmitted Data
SDI-12	Serial – Data Interface standard for microprocessor based sensors
WMO	World Meteorological Organisation

### 13.2 Guarantee

For terms of guarantee contact your supplier.

Warranty is void if the transducer caps have been damaged or the unit is opened up.

## 13.3 WindSonic M

### Electrical Conformity

#### EU Declaration of Conformity

We  
Of  
Gill Instruments Limited  
Saltmarsh Park  
67 Gosport Street  
Lymington  
SO41 9EG  
England

In accordance with the following CE Directives:



Hereby declare under our sole responsibility that the following products have been designed and where appropriate, manufactured and tested in accordance with the applicable requirements of the following European harmonised standards and where applicable, IEC Standards:

#### 1405 WindSonic Anemometer

EMC Emissions & Immunity	<b>EN61326-1:2013</b> <b>EN60945:2002</b>
Restriction of Hazardous Substances	<b>EN50581:2012</b>

Signed by:

Print Name: **R. McKay**

Position: **Product Manager**

Date of Issue: **14<sup>th</sup> February 2017**

Place of Issue: **Gill Instruments Ltd, Lymington**