



Innovations in Water Monitoring

Operator's Manual

RDO[®] PRO-X Process Optical Dissolved Oxygen Probe



Copyright © 2008-2015 by In-Situ All rights reserved.

This document contains proprietary information which is protected by copyright. No part of this document may be photocopied, reproduced, or translated to another language without the prior written consent of In-Situ

In-Situ makes no warranty of any kind with regard to this material, including, but not limited to, its fitness for a particular application. In-Situ will not be liable for errors contained herein or for incidental or consequential damages in connection with the furnishing, performance, or use of this material.

In no event shall In-Situ Inc. be liable for any claim for direct, incidental, or consequential damages arising out of, or in connection with, the sale, manufacture, delivery, or use of any product.

In-Situ and the In-Situ logo, Win-Situ, TROLL, Baro Merge, BaroTROLL, HERMIT, HyroVu™, iSitu, Pocket-Situ, RDO, RuggedCable, RuggedReader, TROLL, and VuSitu™, Win-Situ are trademarks or registered trademarks of In-Situ Inc. Microsoft and Windows are registered trademarks of Microsoft Corporation. Pentium is a registered trademark of Intel. Tefzel and Delrin are registered trademarks of E. I. DuPont de Nemours and Company. Viton is a registered trademark of DuPont Dow Elastomers. Kellems is a registered trademark of Hubbell Inc. Alconox is a registered trademark of Alconox Company. Lime-A-Way is a registered trademark of Reckitt Benckiser. Android is a trademark of Google Inc. iPod and iPhone are trademarks of Apple Inc., registered in the U.S. and other countries. The Bluetooth word mark and logos are registered trademarks owned by the Bluetooth SIG, Inc. and any use of such marks by In-Situ Inc. is under license. NIST is a registered trademark of the National Institute of Standards and Technology, U.S.A. Other brand names and trademarks are property of their respective owners.



The presence of the Waste Electrical and Electronic Equipment (WEEE) marking on the product indicates that the device is not to be disposed via the municipal waste collection system of any member state of the European Union.

For products under the requirement of WEEE directive, please contact your distributor for the proper decontamination information and take back program, which will facilitate the proper collection, treatment, recovery, recycling, and safe disposal of the device.

Table of Contents

1 Optical RDO PRO-X Dissolved Oxygen Probe Specifications	5
2 Introduction	6
System Description	6
Serial Numbers	7
Unpack the Probe	7
3 Calibrate the RDO PRO-X Probe	9
1-Point Calibration	9
Water-Saturated Air	9
2-Point Calibration	9
100% and 0% Saturation	9
4 Probe Deployment	11
5 Care and Maintenance	12
Clean the RDO-X Sensor Cap	12
Clean the Optical Window	12
Clean the Probe	12
RDO-X Sensor Cap Storage	12
Replace the RDO-X Sensor Cap	12
Maintain Desiccant	13
6 Controller Requirements and Connections	14
Wiring Overview	14
Analog (4-20 mA) 3-wire	15
SDI-12 (3-wire)	16
Modbus Master with Built-in RS485	17
Modbus Master with Built-in RS232 (Converter Required)	18
Converter	19
Power Connections	19
Communications	19
7 Modbus Registers	20
Common Registers	20
Sensor Status Registers	20
Device Specific Register 0042 Data Quality ID	20
Device Specific Registers	21
8 Dissolved Oxygen Equations	22
Dissolved Oxygen Concentration	22
Dissolved Oxygen, % Saturation	23
9 Calibration Registers	24
Live Salinity Value	24
Default Salinity Value	24
Live Barometric Pressure	24
Default Barometric Pressure	24

100% Saturation Calibration Values	24
0% Saturation Calibration Values	24
Calibration Slope and Offset	25
Entering Calibration Registers	25
Calibration Calculations	26
10 Service	27
Sensor Health Table	27
11 Appendix A - Communication Device	28
Install and Open the Software	28
Connect the Probe to the Communication Device	28
12 Declaration of Similarity	29

Optical RDO PRO-X Dissolved Oxygen Probe Specifications

Optical RDO PRO-X Dissolved Oxygen Probe	
Sensor Type	Optical (luminescent) dissolved oxygen sensor
RDO PRO-X Probe	Range: 0 to 50 mg/L concentration
	Accuracy: ± 0.1 mg/L, 0 to 8 mg/L ± 0.2 mg/L, 8 to 20 mg/L $\pm 10\%$ of reading, 20 to 50 mg/L
	Resolution: 0.01 mg/L
	Response time: T90 < 45 sec; T95 < 60 sec @ 25°C
	Storage conditions: -5° to 60° C (23° to 140° F)
RDO-X Sensor Cap	Usage life: 2 years typical
	Storage conditions: 1° to 60° C (33° to 140° F), in factory container
Temperature sensor	Range: 0° to 50° C (32° to 122° F)
	Accuracy: $\pm 0.1^\circ$ C typical
	Resolution: 0.01° C
Transmitter/local display	Optional, or use with Con TROLL PRO System
Communications options	Modbus/RS485, 4-20 mA, SDI-12
Max. power consumption	50 mA at 12 VDC
Measure current	6 mA typical at 24 VDC
Idle current (no measurement or communication)	160 μ A typical at 24 VDC
Maximum cable length	Up to 1,219 m (4,000 ft) (for Modbus and 4-20 mA) or up to 60.96 (200 ft) for SDI-12
Cable options	10 m fixed stripped-and-tinned; Twist-lock connector with user-selectable cable length
Internal mounting thread	1¼ - 11 ½ NPT
IP rating	IP-67 with cap off, IP-68 with cap installed
Compliance	Heavy industrial, IEC 61000-6-2:2005
Salinity compensation	Fixed or real-time capable (using controller)
Barometric pressure	Fixed or real-time capable (using controller)
Maximum pressure	150 psi from 0 to 50° C; 300 psi @ 25° C
Warranty	Probe: 3 years from date of shipment RDO-X Sensor Cap: 2 years in typical applications
Methods	Standard Methods 4500-O; In-Situ Methods 1002-8-2009, 1003-8-2009, 1004-8-2009 (EPA approved)

Introduction

The RDO PRO-X Probe is a rugged, reliable instrument designed to deliver accurate dissolved oxygen (DO) data across a wide measurement range and to reduce maintenance costs. The probe features the latest optical technology for DO measurement.

System Description

The RDO PRO-X system consists of the following items.

- Black probe body with removable nose cone
- Optical RDO-X Sensor Cap
- Titanium thermistor

RuggedCable System

- 10-m standard length with stripped-and-tinned ends
- Customized lengths with titanium twist-lock connectors



1	Cable end, stripped-and-tinned
2	Nose cone
3	RDO-X Sensor Cap
4	Thermistor



1	Probe
2	Cable end, twist-lock connector and RuggedCable System

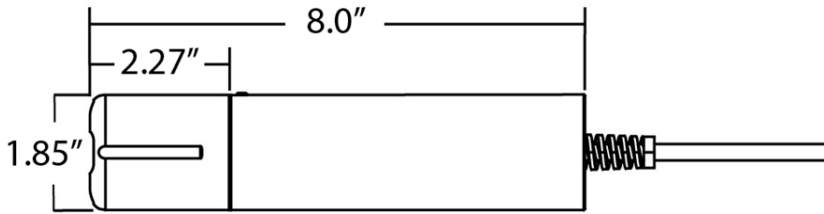

Serial Numbers

The probe serial number is engraved on the side of the unit. The cap serial number is programmed on the memory chip inside the cap.

Unpack the Probe

1. Remove the probe from the box and other packaging materials.
2. Unscrew the nose cone from the probe and remove the red protective dust cap from the sensor. Save the dust cap for later use.

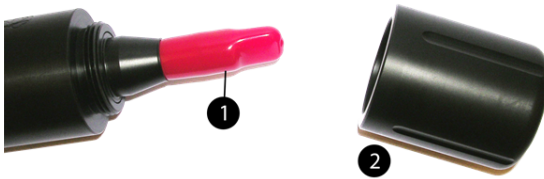

1	Dust cap
2	Nose cone

3. Remove the RDO cap from the storage sleeve.



4. Align the arrow on the cap with the index mark on the probe and firmly press the cap onto the probe, without twisting, until it seals over the probe body.



- | | |
|---|-------------------------|
| 1 | Alignment arrow on cap |
| 2 | Cap installed over lens |
| 3 | Nose cone |

✓ Do not allow moisture or atmospheric humidity inside the cap. Keep the cap in its sealed package until you are ready to install it. Install promptly. Ensure that O-ring grooves are dry and that the O-ring is not rolled or pinched inside the cap. The typical cap lifetime is two years after the first reading has been taken.

5. Reattach the nose cone.

Calibrate the RDO PRO-X Probe

Calibrate the sensor with the Comm Kit Software and the RDO PRO Communication Device, or calibrate the sensor directly with your controller.

1-Point Calibration

The optical Rugged Dissolved Oxygen sensor is very stable. The factory calibration should produce readings within 3% accuracy. If you require readings with greater accuracy we recommend that you perform a 1-point, 100% water-saturated air calibration as described below.

Water-Saturated Air

1. Remove the storage cap from the top of the calibration chamber and replace it with the vented calibration cap.



1	Storage cap
2	Vented calibration cap

Figure 6.1 Storage cap and vented calibration cap shown together

2. Place the sponge wafer in the bottom of the calibration chamber and saturate with approximately 10 mL water.
3. Gently dry the instrument and sensing material with a paper towel, making sure there is no water or debris on the instrument or on the sensing surface.
4. Place the instrument into the calibration chamber about 2.5 cm (1 in.) above the water-saturated sponge.



Figure 6.2 Calibration chamber with water-saturated sponge

5. Allow 5 to 10 minutes for temperature stabilization prior to starting the calibration procedure. Do not leave the instrument in the calibration chamber for more than 30 minutes. This can allow condensation to form on the sensing material, which will produce false low readings after calibration. If condensation does occur, remove the instrument, dry the sensing material, place the instrument in the chamber, and calibrate.

2-Point Calibration

100% and 0% Saturation

We recommend that you perform the 0 % oxygen calibration only if you intend to measure dissolved oxygen at a concentration of less than 4 mg/L.

-
1. Set up the calibration procedure as previously described, and perform a water-saturated air calibration.
 2. Remove the water-saturated sponge from the calibration chamber and fill the chamber to the fill line with approximately 60 mL of fresh sodium sulfite solution.



1	Fill line
2	Temperature sensor

2. Place the instrument into the solution. Leave at least 13 mm (0.5 in.) between the surface of the sensing material and the bottom of the chamber.
3. Ensure that the temperature sensor is completely submerged in the solution.
4. Allow at least 5 minutes for the temperature to stabilize prior to performing the calibration procedure.
5. Once calibration is complete, remove the sensor, and thoroughly rinse to remove all of the sodium sulfite.

Probe Deployment

The cable end of the RDO PRO-X Probe is internally threaded (1¼ – 1½ NPT) and can be attached to a male threaded pipe. When deployed, make sure that the nose cone and thermistor are completely submerged.

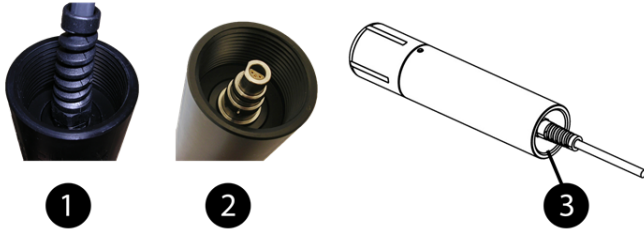

1	10 m cable attached
2	Twist-lock connector
3	1 1/4 NPT threading

Care and Maintenance

Clean the RDO-X Sensor Cap

1. The cap and nose cone must remain on the probe.
2. Rinse the sensor with clean water from a squirt bottle or spray bottle.
3. Gently wipe with a soft-bristled brush or soft cloth if biofouling is present. Use Alconox to remove grease.
4. If extensive fouling or mineral build-up is present, soak the cap end in vinegar for 15 minutes, then soak in deionized (DI) water for 15 minutes.



Do not use organic solvents—they will damage the sensing element. Do not remove the cap from the sensor prior to cleaning.

5. After cleaning, perform a 1- or 2-point user calibration or calibration check.

Clean the Optical Window

1. Clean the optical window only when you change the cap. See full instructions in the sensor cap replacement kit.
2. Remove the cap and gently wipe the lens with the supplied lens cloth.



Do not wet the lens area with water or any solution. Use only the supplied lens cloth for cleaning. Do not use any other cloth or material.

Clean the Probe

With the RDO cap installed on probe, gently scrub the probe with a soft-bristled brush or nylon dish scrubber. Use Alconox to remove grease or other matter. Soak in vinegar and DI water to remove mineral deposits or extensive fouling.

RDO-X Sensor Cap Storage

Prior to installation—Store in factory supplied container.

Installed—Store in the calibration chamber with the storage cap attached and a few drops of clean water.

Replace the RDO-X Sensor Cap

The RDO cap has a 2-year typical life after the sensor takes its first reading. Replacement caps are available from In-Situ Inc. or your authorized In-Situ distributor.

1. Remove the probe nose cone.
2. Use a lint-free cloth to remove any moisture from the probe.
3. Pull the used RDO cap off of the sensor, without twisting.
4. Remove the existing O-rings from the sensor.



Ensure that there is no moisture in the O-ring grooves. Do not touch or clean the lens with anything other than the supplied lens wipe.

5. Use your finger to apply a very light layer of silicone-based lubricant around the O-ring grooves.
6. Place the O-rings on the sensor. Apply another thin layer of lubricant to the O-rings and grooves.



Note: Do not transfer grease to the lens or sensor pins.

7. Clean the sensor lens with the wipe provided in the kit and allow it to thoroughly dry. Inspect for scratches or dirt.

-
8. Remove the new cap from its sealed packaging and attach it to the sensor, being careful to press firmly, without twisting, until it seals over the lens. Make sure that the O-rings are not pinched or rolled between the cap and sensor.
 9. Replace the nose cone.
 10. Perform a 1- or 2-point calibration.

Maintain Desiccant

Desiccant installed in a controller or transceiver protects probe electronics from condensation. A desiccant pack changes color from blue to pink as it becomes saturated with moisture.



It is extremely important to use the proper size desiccant for your deployment and to change desiccant often. Desiccant should be changed before the entire pack has turned pink, and you should use enough to effectively keep cables and probes dry until your next scheduled maintenance. Desiccant lifespan is dependent on site conditions.

Controller Requirements and Connections

The RDO PRO-X Probe may be connected to a controller or logger for communication via the following options.

- Analog (4-20 mA) provides a configurable 4-20 mA current loop output
- SDI-12
- RS485 Modbus
- RS232 to Modbus

Wiring Overview

Refer to diagrams on the following pages. Trim and insulate unused wires. The shielded wire should be connected to a chassis ground or earth ground.

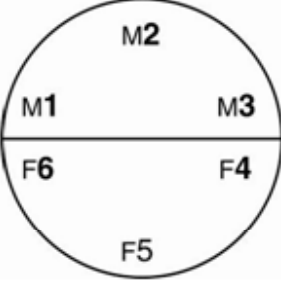
	Signal	Color
	Ground/Return	Black
	External Power	Red
	4-20 mA	Brown
	RS485 (-)	Green
	RS485 (+)	Blue
	SDI-12	White



The inside of the controller must be kept free of moisture and humidity. Condensed moisture can migrate through the wiring and cause the probe to fail. Therefore, desiccant should be installed in the controller and be replaced on a regular basis.

Analog (4-20 mA) 3-wire

Signal	Color
Ground/Return	Black
External Power (12-36 VDC)	Red
4-20 mA	Brown

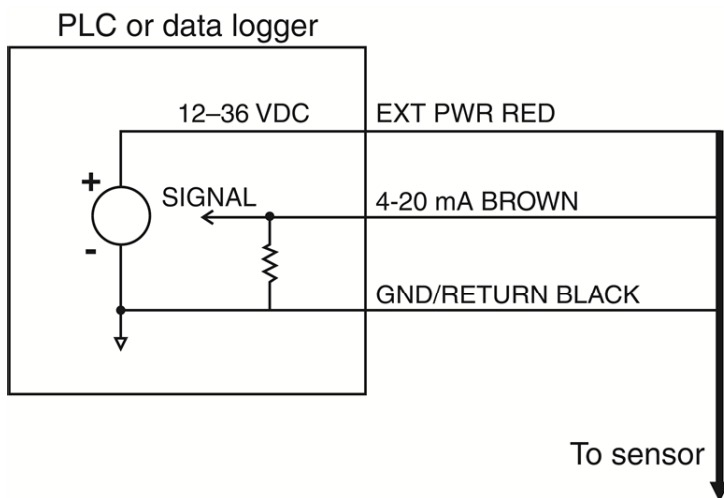

Cable length must not exceed 1219 m (4000 ft.)
Analog signal must be enabled in Win-Situ 5 Software or the Comm Kit Software prior to use.

SDI-12 (3-wire)

Signal	Color
Ground/Return	Black
External Power (9.6-16 VDC)	Red
RS485 (-)	Green
RS485 (+)	Blue
SDI-12	White

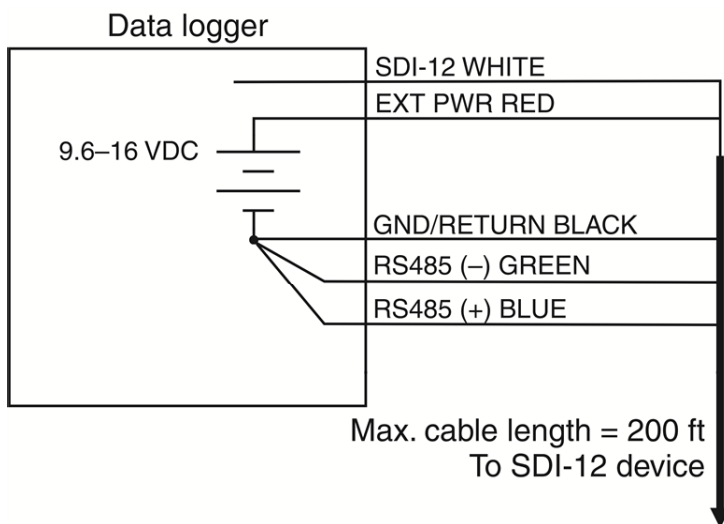

✓ Cable length must not exceed 60.96 m (200 ft.)

Modbus Master with Built-in RS485

Signal	Color
Ground/Return	Black
External Power (12-36 VDC)	Red
RS485 (-)	Green
RS485 (+)	Blue

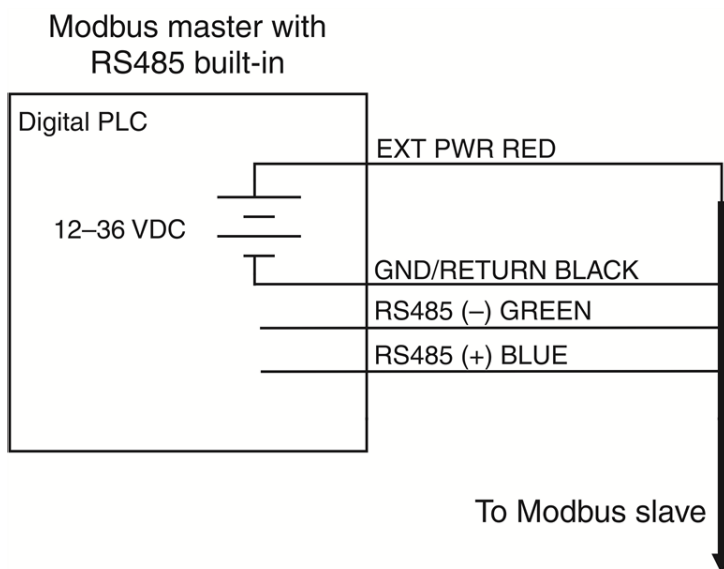

✓ Cable length must not exceed 1219 m (4000 ft.)

Modbus Master with Built-in RS232 (Converter Required)

Signal	Color
Ground/Return	Black
External Power (12 VDC, voltage limited by converter)	Red
RS485 (-)	Green
RS485 (+)	Blue

Modbus master with
RS232 built-in
(converter required)

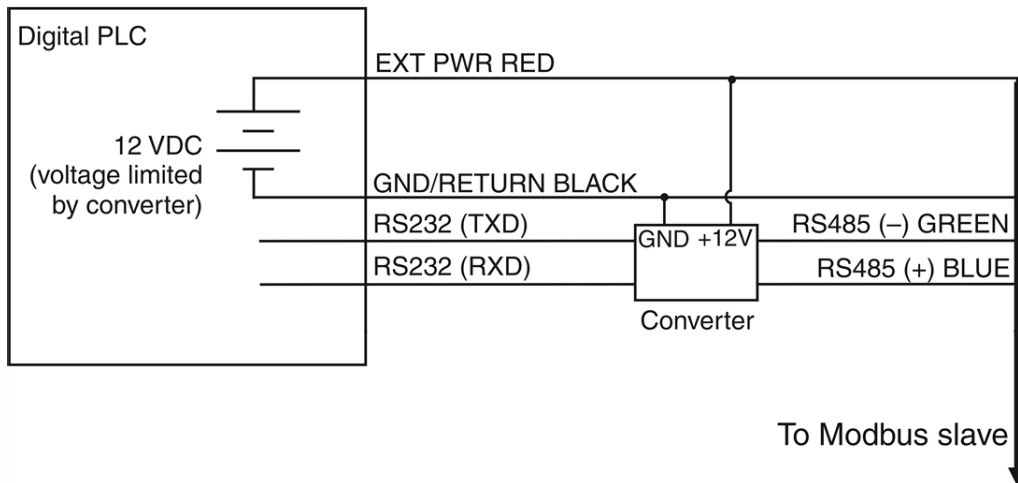

✓ Cable between converter and master must not exceed 60.96 m (20 ft.)
Cable between master and slave must not exceed 1219 m (4000 ft.)

Converter

Port-powered RS485 converter, such as B&B Electronics Model 485SD9TB

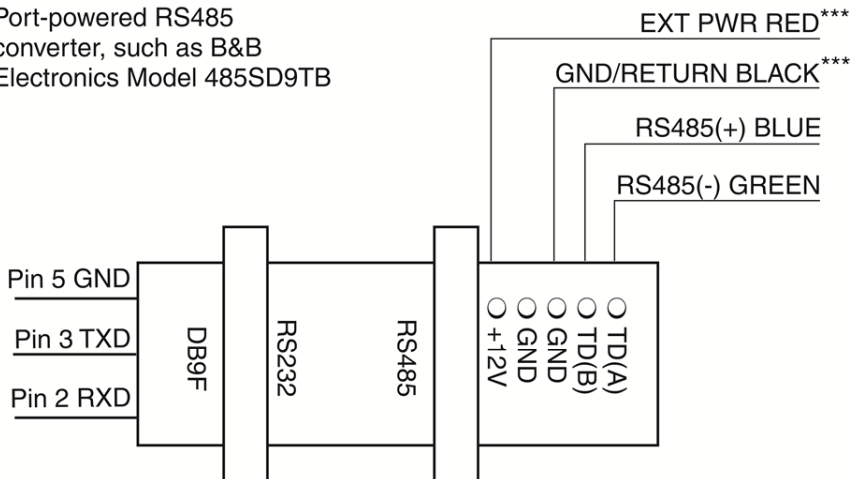

*** Required if port power is not available

Power Connections

The red wire provides power for all system modes. Analog output is disabled by default. However, the 4-20 mA current loop output can be continuous in Modbus or SDI-12 mode as long as Modbus device register 9507 is set to 1.

Communications

The device automatically switches between Modbus and SDI-12 modes depending on which of the two interfaces has activity. Modbus and SDI-12 cannot be used at the same time—whichever one is currently in use will block communication on the other.

Modbus Registers

Common Registers

Register	Size	Mode & Access Level (R/W)	Data Type	Description
9001	1	R/W	ushort	Device ID = 31 for RDO PRO-X
9002	2	R/W	ulong	Device serial number
9004	3	R/W	time	Manufacture date

Sensor Status Registers

Register	Size	Mode & Access Level (R/W)	Data Type	Description
0005	3	R1	time	Cap start date/time 0 = no cap
0008	3	R1	time	Cap end of usable life date/time 0 = no cap

Device Specific Register 0042 Data Quality ID

Register 0042 is responsible for returning the various data quality IDs for the RDO sensor. For a list of the Data Quality IDs and definitions, see the Sensor Health Table in the Service and Troubleshooting section of this manual.

Device Specific Registers

Register	Size	Mode & Access Level (R/W)	Data Type	Description
Dissolved Oxygen Concentration				
0038	2	R1	float	Measured value, C _o
0040	1	R1	ushort	Parameter ID = 20
0041	1	R1/W2	ushort	Units ID 117 = mg/L (default) 118 = ug/L
0042	1	R1	ushort	Data quality ID (See the Sensor Health Table)
0043	2	R1/W3	float	Offline sentinel value (default = 0.0)
0045	1	R1	16 bits	Available units = 0x0030 (48)
Temperature				
0046	2	R1	float	Measured value
0048	1	R1	ushort	Parameter ID = 1
0049	1	R1/W2	ushort	Units ID 1= °C (default) 2= °F
0050	1	R1	ushort	Data quality ID
0051	2	R1/W3	float	Offline sentinel value (default = 0.0)
0053	1	R1	16 bits	Available units = 0x00030 (3)
Dissolved Oxygen % Saturation				
0054	2	R1	float	Measured value
0056	1	R1/W2	ushort	Parameter ID = 21
0057	1	R1/W2	ushort	Units ID 177 = percent saturation (default)
0058	1	R1	ushort	Data quality ID
0059	2	R1/W3	float	Offline sentinel value (default = 0.0)
0061	1	R1	16 bits	Available units = 0x0001 (1)
Oxygen Partial Pressure				
0062	2	R1	float	Measured value
0064	1	R1	ushort	Parameter ID = 2 (pressure)
0065	1	R1/W2	ushort	Units ID 26 = torr (default)
0066	1	R1	ushort	Data quality ID
0067	2	R1/W3	float	Offline sentinel value (default = 0.0)
0069	1	R1	16 bits	Available Units = 0x0200 (512)

Dissolved Oxygen Equations

Dissolved Oxygen Concentration

DO concentration is internally calculated in mg/L. Conversion to other units is as follows:

$$\mu\text{g/L} = 1000 * \text{mg/L}$$

Oxygen concentration C_o (mg/L) is calculated as:

$$C_o = 31.9988 \times 1E6 \times (\rho P_o / k_o M) (1 - \Theta_o) \times S_c$$

Where:

P_o is the partial pressure of O_2 in atmospheres.

$$P_{\text{torr}} = 759.999876 \times P_{\text{atm}}$$

S_c is the salinity correction:

$$\ln S_c = S(B_0 + B_1 T_s + B_2 T_s^2 + B_3 T_s^3) + C_0 S^2$$

$$B_0 = -6.246090 \times 10^{-3}$$

$$B_1 = -7.423444 \times 10^{-3}$$

$$B_2 = -1.048635 \times 10^{-2}$$

$$B_3 = -7.987907 \times 10^{-3}$$

$$C_0 = -4.679983 \times 10^{-7}$$

T_s is the scaled temperature:

$$T_s = \ln [(298.15 - t) / (273.15 + t)]$$

t is temperature in degrees C.

S is the salinity in PSU.

k_o is Henry's constant:

$$\ln k_o = 3.71814 + (5596.17/T) - (1,049,668/T^2)$$

T is temperature in Kelvin.

Θ_o is the negative of the second pressure coefficient:

$$\Theta_o = 0.000975 - (1.426 \times 10^{-5}t) + (6.436 \times 10^{-8}t^2)$$

t is temperature in degrees C.

ρ is the density of water in g/cm^3 :

$$\ln \rho = -0.589581 + (326.785/T) - (45,284.1/T^2)$$

T is the temperature in Kelvin.

Molar mass of water: $M = 18.0152 \text{ g/mole}$

References:

Benson and Krause, Jr.. 1980. The concentration and isotopic fractionation of gases dissolved in freshwater in equilibrium with the atmosphere. *Limnol, Oceanogr*, 25(4), 662-671.

Gordon and Garcia. 1992. Oxygen Solubility in Seawater: Better Fitting Equations. *Limnol, Oceanogr*, 37(6), 1307-1312.

Dissolved Oxygen, % Saturation

$$O_2\%Sat = O_2Reading / O_2100\%Sat$$

Where:

O₂ reading is the mg/L reading from the RDO Sensor.

O₂ 100% Sat is the theoretical saturation value in mg/L and is derived as:

$$O_2100\%Sat = 31.9988 \times 10^6 \times \rho \frac{[0.20946 \times (P - P_{ww})] \times (1 - \Theta_o P) \times S_c}{k_o M}$$

Where:

ρ is the density of water in g/cm³:

$$\ln \rho = -0.589581 + (326.785/T) - (45,284.1/T^2)$$

T is the temperature in Kelvin.

P is the atmospheric pressure in atm.

P_{ww} is the partial pressure of water vapor at saturation in atm:

$$\ln P_{ww} = 11.8571 - (3,840.70/T) - (216,961/T^2)$$

k_o is Henry's constant:

$$\ln k_o = 3.71814 + (5596.17/T) - (1,049,668/T^2)$$

T is the temperature in Kelvin.

Molar mass of water: M = 18.0152 g/mole

Θ_o is the negative of the second pressure coefficient:

$$\Theta_o = 0.000975 - (1.426 \times 10^{-5}t) + (6.436 \times 10^{-8}t^2)$$

t is temperature in degrees C.

S_c is the salinity correction:

$$\ln S_c = S(B_0 + B_1T_s + B_2T_s^2 + B_3T_s^3) + C_0S^2$$

$$B_0 = -6.246090 \times 10^{-3}$$

$$B_1 = -7.423444 \times 10^{-3}$$

$$B_2 = -1.048635 \times 10^{-2}$$

$$B_3 = -7.987907 \times 10^{-3}$$

$$C_0 = -4.679983 \times 10^{-7}$$

T_s is the scaled temperature:

$$T_s = \ln [(298.15 - t) / (273.15 + t)]$$

Where t is temperature in °C

S is the salinity in PSU

References:

Benson and Krause. Jr.. 1980. The concentration and isotopic fractionation of gases dissolved in freshwater in equilibrium with the atmosphere. *Limnol, Oceanogr*, 25(4), 662-671.

Calibration Registers

Register	Size	Mode & Access Level (R/W)	Data Type	Description
0118	2	R1/W3	float	Live salinity value (PSU)
0120	2	R1/W3	float	Default salinity value (PSU, default = 0.0)
0122	2	R1/W3	float	Live barometric pressure (mbar)
0124	2	R1/W3	float	Default barometric pressure (mbar, default = 1013.25)
0126	2	R1/W3	float	100% saturation calibration reading (mg/L)
0128	2	R1/W3	float	100% saturation temperature reading (°C)
0130	2	R1/W3	float	100% saturation salinity value (PSU)
0132	2	R1/W3	float	100% saturation barometric pressure (mbar)
0134	2	R1/W3	float	0% saturation calibration reading (mg/L)
0136	2	R1/W3	float	0% saturation temperature reading (°C)
0138	2	R1/W3	float	Calibration slope (default = 1.0)
0140	2	R1/W3	float	Calibration offset (default = 0.0)

Live Salinity Value

The live salinity value is used to correct the oxygen concentration value for salinity. Values must be written in Practical Salinity Units (PSU) in the range 0 to 42 PSU. This is not a measured parameter.

Default Salinity Value

The default salinity value is loaded into the live salinity value register when power is first applied to the probe. The default salinity value is used in calculations until a live salinity value is written. This is not a measured parameter.

Live Barometric Pressure

The live barometric pressure is used in the calculation of percent saturation and to determine the theoretical saturation point during calibration. Values must be written in millibars in the range 506.625 to 1114.675 mbar. This is not a measured parameter.

Default Barometric Pressure

The default barometric pressure is loaded into the live barometric pressure register when power is applied to the probe. The default barometric pressure is used in calculations until a live barometric pressure is written. This is not a measured parameter.

100% Saturation Calibration Values

These values represent the sensor conditions while the probe is in a 100% saturation calibration environment. These are not measured values, they are written by the controller during the calibration process.

Writes to these registers are only accepted if the probe is in the calibration mode. The probe will return exception 0x85 (invalid device command sequence) if an attempt is made to write these registers when the calibration mode is off.

0% Saturation Calibration Values

These values represent the sensor conditions while the probe is in a 0% saturation calibration environment. These are not measured values, they are written by the controller during the calibration process.

Writes to these registers are only accepted if the probe is in the calibration mode. The probe will return exception 0x85 (invalid device command sequence) if an attempt is made to write these registers when the calibration mode is off.

Calibration Slope and Offset

These values represent the slope and offset that will be applied to the raw concentration reading from the sensor to generate the final values reported by the sensor parameters. These registers may be written independently of the normal internal calibration procedure.

Entering Calibration Registers

The sensor is calibrated using the following procedure.

1. Optional: Read the Sensor Data Cache Timeout register 9463 and store the value.
2. Write the Sensor Data Cache Timeout register 9463 to a value less than your intended sample rate and greater than 1000 milliseconds. This will ensure that you get new sensor readings during the stabilization process.
3. Optional: Read the temperature units register 0049 and saturation units register 0041 and store their values.
4. Write the temperature units register 0049 to its default value (1) and write the saturation units register 0041 to its default value (117).
5. Write the Calibration Mode On command (0xE00) to the sensor command register 9305.
6. Update the live salinity and barometric pressure registers if necessary.
7. Prompt the user to place the probe in a 100% saturation environment.
8. Read the oxygen concentration and temperature parameters. When these values have reached equilibrium, record them in their respective 100% saturation calibration registers. Write the current live salinity and barometric pressure readings to their respective calibration registers.
9. Place the sensor in a 0% saturation environment. When these registers have reached equilibrium, record them in their respective 0% saturation calibration registers. If a zero calibration is not to be performed, these registers can be set to zero or left at their previous values.
10. Write the Calibration Update command (0xE001) to the sensor command register. The sensor will calculate a new slope and offset, write the current time to the last user calibration time register, and set the next user calibration time register to zero (disabled). If the concentrations at 100% and 0% saturation are equal, the probe will return an exception response with code 0x97 (invalid calibration) and not attempt to compute a new slope and offset due to possible division by zero. If the slope does not calculate between 0.85 and 1.20 inclusive, or if the offset does not calculate between -0.2 and +0.2 inclusive, then the probe will return an exception response with code 0x97 (invalid calibration). The slope and offset will be available for read but will not be committed to flash.
11. Optional: Read the last user calibration time register, add the next calibration interval, and write the result to the next user calibration time register.
12. Write the Calibration Mode Off command (0xE002) to the sensor command register to place the sensor in normal operation. If the calibration mode is turned off without a calibration update command, or the calibration command returned an exception, the previous calibration shall be restored.
13. Optional: If you saved the temperature and saturation parameter units at the start of the process, write the original values back.
14. Optional: If you saved the Sensor Data Cache Timeout register 9463 at the start of the process, write the original value back.

Calibration Calculations

Calibrated oxygen reading:

$$O_{2RC} = C_0 + C_1 \times O_{2RU}$$

Where:

$$C_1 = (O_2100\%Sat) / (O_{2RUS} - O_{2RUZ})$$

$$C_0 = -C_1 \times O_{2RUZ}$$

Where:

$O_2100\%Sat$ is the theoretical 100% saturation point

O_{2RUS} is the un-calibrated reading at 100% saturation

O_{2RUZ} is the un-calibrated reading at 0% saturation

References:

Standard Methods for the Examination of Water and Wastewater. 20th Ed. 2008. 4500-0 C. Azide Modification. American Public Health Association, USA.

Service

The RDO PRO-X Probe contains no user-serviceable parts. Do not attempt to open the probe case or service the unit yourself.

RDO-X Software Troubleshooting



Sensor health diagnostics indicate when the RDO sensor has been damaged in the field. If the sensor has sustained moderate damage, the probe provides a DO value that includes a (DIS or Data Quality ID 5) warning. The same warning is included with readings taken after the sensor has reached its 24-month recommended lifespan.

However, if the sensor has been severely damaged, an error message is shown (ERR or Data Quality ID 3), a DO value is not provided and the sentinel value is shown. This prevents you from receiving an erroneous reading.

Sensor Health Table

The following error messages appear in the software and the data file when a sensor issue has been detected.

Abbreviation	Data Quality ID	Text	Description
None	0	None	Normal Data Quality
UC	1	User Cal Expired	Parameter measured without errors using an expired user calibration.
FC	2	Factory Cal Expired	Parameter measured without errors using an expired factory calibration.
ERR	3	Unknown Error	Parameter measured with error, sentinel value supplied.
WU	4	Sensor Warm-up	Sensor is warming up, sentinel value supplied.
DIS	5	Sensor Warning	Parameter measured but does not meet normal quality criteria. The sensor has sustained moderate damage, or the recommended lifespan has been reached.
CAL	6	Sensor Calibrating	Sensor is calibrating, calibration value supplied.
OL	7	Sensor Missing	Sensor communication failed, sentinel value supplied. Make sure the sensor cap is installed and properly seated.

Appendix A - Communication Device

The Communication Device is an accessory product that can be used to calibrate and set up RDO probes.

Install and Open the Software

The Comm Kit Software must be installed on a computer before you connect to the probe.

Connect the Probe to the Communication Device

The Communication Device connects a stripped-and-tinned probe to a computer via USB connection.

1. Disconnect the instrument from the PLC.
2. The communication device includes an electrical connection diagram label. To attach the instrument to the communication device, depress a lever and insert the appropriate wire in the location specified by the diagram.
3. Attach the USB connector to a USB port on the computer. Follow the directions provided in the Communication Device Kit to set up the probe.

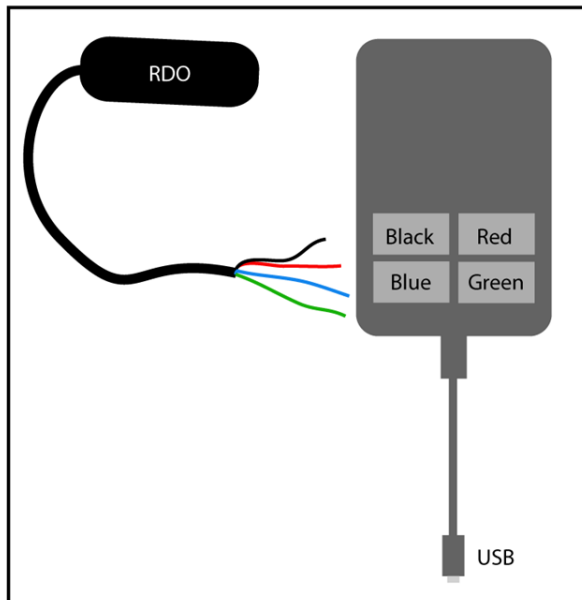

Declaration of Similarity

Equipment

Type of equipment: Measurement instrumentation
Product name: RDO PRO-X Optical Dissolved Oxygen Probe
Model: RDO PRO-X Dissolved Oxygen Probe

Manufacturer: In-Situ, Inc.
221 East Lincoln Avenue
Fort Collins, CO 80524
USA

Category Standards

- **Immunity**
EN 61000-6-2, Electromagnetic Compatibility (EMC) – part 6-2: Generic standards – Immunity for industrial environments
- **Emissions**
Class A requirements of CISPR 11: 2004, Specification for limits and methods of measurement of radio disturbance characteristics of industrial, scientific and medical (ISM) radio-frequency equipment

Supplementary Information:

The device complies with the requirements of the EU Directive 73/23/EEC, and the CE mark is affixed accordingly.

Summary

We confirm that the equipment referenced above, without reasonable doubt, will fulfill the requirements concerning electromagnetic compatibility according to the above mentioned standards harmonized with the 2004/108/EC for Electromagnetic Compatibility (EMC) Directive—part 6-2. The RDO PRO Optical Dissolved Oxygen Sensor was tested and found to be in compliance in the month of October 2008.

Date of Issue: October 7, 2013

Signature: 

Name: Ben Kimbell
Title: Vice President of Research and Development

Test Report reference: 3161946DEN-003

